



Pass-Thru Refrigerator Service Manual

i.Series™ and Horizon Series™



Blood Bank Models

- i.Series: iB225, iB456 (Version B)
- Horizon Series: HB225, HB456 (Version B)

Pharmacy / Laboratory Models

- i.Series: iPR225, iPR456 (Version B)
- Horizon Series: HPR225, HPR456 (Version B)

Model _____

S/N _____



ISO 13485:2003 CERTIFIED



HELMER, INC.
14395 Bergen Boulevard
Noblesville, IN 46060 USA
Phone +1 (317) 773-9073
USA and Canada (800) 743-5637

Contents

Section I: General Information	1
1 About this Manual	3
2 Safety	4
2.1 Labels	4
2.2 Avoiding injury	4
3 Configuration	5
3.1 Finding model and input power information	5
3.2 Identifying the control system	5
3.3 Preparing temperature probes	6
3.4 Preparing the chart recorder	7
Section II: i.Series™ Models	9
4 Product Configuration	11
4.1 Installing batteries for backup power	11
4.2 Refrigerator setpoint configuration	12
4.5 External monitoring devices	13
4.6 Moving drawers, shelves, and baskets	14
4.7 Door characteristics	16
4.8 Connecting to the internal outlet	16
5 Temperature Controller Programs	17
5.1 Temperature setpoint settings	17
5.2 Temperature calibration settings	18
6 Maintenance	20
6.1 Recharging refrigerant	20
6.2 Checking the monitoring system backup battery	21
6.3 Replacing LED lamps	21
6.4 Cleaning the refrigerator	22
6.5 Removing and installing the unit cooler cover	23
6.6 Supplies	24
7 Troubleshooting	25
7.1 General operation problems	25
7.2 Chamber temperature problems	26
7.3 Alarm activation problems	27
7.4 Testing problems	30
7.5 Condensation problems	31
8 Parts	32
8.1 Front (control side)	32
8.2 Top	34
8.3 Bottom	36
8.4 Interior	37
9 Schematics	41
9.1 iB, and iPR models; 225 and 456 configurations	41

10 Settings	.43
10.1 Navigating the Home screen	.43
10.2 Viewing and changing settings	.44
10.3 Testing alarms	.47
10.4 Upgrading the system firmware	.50
10.5 Calibrating the touchscreen	.50
10.6 Viewing manufacturer and product information	.50
11 Warranty	.51
11.1 Rel.i™ Product Warranty USA and Canada	.51
11.2 Outside of USA and Canada	.52
12 References and Compliance	.53
D.1 Alarm reference	.53
D.2 Energy conservation and regulatory compliance	.53
Section III: Horizon Series™ Models	.55
13 Product Configuration	.57
13.1 Installing batteries for backup power	.57
13.2 Refrigerator setpoint configuration	.58
13.3 External monitoring devices	.59
13.4 Moving drawers, shelves, and baskets	.60
13.5 Door characteristics	.62
13.6 Connecting to the internal outlet	.62
14 Temperature Controller Programs	.63
14.1 Hysteresis	.63
14.2 High alarm setpoint	.63
14.3 Low alarm setpoint	.63
14.4 Control temperature offset value	.63
14.5 Monitor temperature offset value	.63
15 Maintenance	.64
15.1 Recharging refrigerant	.64
15.2 Checking the monitoring system backup battery	.65
15.3 Replacing LED lamps	.65
15.4 Cleaning the refrigerator	.66
15.5 Removing and installing the unit cooler cover	.67
15.6 Supplies	.68
16 Troubleshooting	.69
16.1 General operation problems	.69
16.2 Chamber temperature problems	.70
16.3 Alarm activation problems	.71
16.4 Condensation problems	.73
17 Parts	.74
17.1 Front (control side)	.74
17.2 Top	.75
17.3 Bottom	.77
17.4 Interior	.78

18 Schematics82
18.1 HB and HPR models; 225, and 456 configurations82
19 Settings83
19.1 Touring the monitoring and control system83
19.2 Viewing current settings84
19.3 Changing settings85
19.4 Testing alarms87
20 Warranty89
20.1 Rel.i™ Product Warranty USA and Canada89
20.2 Outside of USA and Canada90
21 References and Compliance91
21.1 Alarm reference91
21.2 Energy conservation and regulatory compliance91

This page left blank intentionally.

Section I: General Information

This page left blank intentionally.

1 About this Manual

This chapter explains the symbols and conventions used in this manual, copyright information about this document, and trademark information for products supplied by Helmer.

1.1 Intended audience

This manual is intended for use by authorized end users and qualified service technicians, and is to be used in conjunction with the i.C³™ User Guide, Pass-Thru Refrigerator Operation Manual, and the Chart Recorder Operation Manual, available on the CD shipped with the refrigerator.

1.2 Symbols and conventions

1.2.1 Cautions

A Caution is used to call attention to a condition or possible situation that could damage or destroy the equipment or the operator's work.



CAUTION

Temperature probes are fragile. Handle them with care.

1.2.2 Notes

Notes contain additional information about a topic. Notes are used to provide information about how a topic relates to another topic, or background information about a design characteristic.

NOTE

Spare parts are available for purchase through Helmer.

1.2.3 Model references

Generic references are used throughout this manual to group models that contain similar features. For example, "225 models" refers to all models of that size (iB225, iPR225, HB225, HPR225). This manual covers all pass-thru refrigerators, which may be identified singly, by their size, or by their respective "Series."

Model Group	i.Series	Horizon Series
Blood Bank	iB225, iB456	HB225, HB456
Pharmacy / Laboratory	iPR225, iPR456	HPR225, HPR456

1.3 Copyright and trademark information

Helmer®, i.Series®, i.C³™, Horizon Series™, and Rel.i™ are registered trademarks or trademarks of Helmer, Inc. in the United States of America. Copyright © 2012 Helmer, Inc. All other trademarks and registered trademarks are the property of their respective owners.

2 Safety

This chapter describes general safety information for servicing the refrigerator. The Pass-Thru Refrigerator Operation Manual includes additional safety information for operating the refrigerator. Your organization may provide additional safety information.

2.1 Labels



Caution, risk of danger



Caution, hot surface

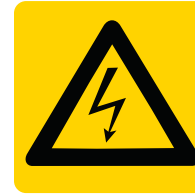

Caution, shock hazard

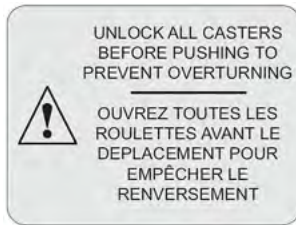

Caution, unlock all casters

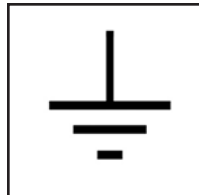

Earth ground terminal

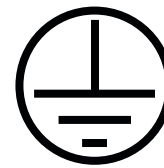

Protective earth ground terminal

2.2 Avoiding injury

- ▶ Review safety instructions before installing, using, or maintaining the equipment.
- ▶ Before performing procedures, review any specific safety instructions.
- ▶ Do not open multiple, loaded drawers at the same time.
- ▶ Before moving unit, ensure casters are free of debris.
- ▶ Do not move a single-door unit whose load exceeds 900 lbs (408 kg) or a double-door unit whose load exceeds 1350 lbs (613 kg).
- ▶ Avoid removing electrical service panels and access panels unless so instructed.
- ▶ Use supplied power cords only.
- ▶ Notify appropriate safety personnel when handling or disposing of materials that are infectious, toxic, pathological, radioactive, or otherwise biologically or environmentally harmful.



CAUTION

Decontaminate parts prior to sending for service or repair. Items not decontaminated appropriately will not be accepted. Documentation stating contents are not contaminated and are safe to handle must accompany returns. Contact Helmer or your distributor for decontamination instructions and a Return Authorization Number.

3 Configuration

3.1 Finding model and input power information

Service information varies depending on the model and input power requirements. This information appears on the Product Specification label, located on the rear of the refrigerator below the electrical box. The model also appears on a label located in the chamber on the upper side of the right wall.

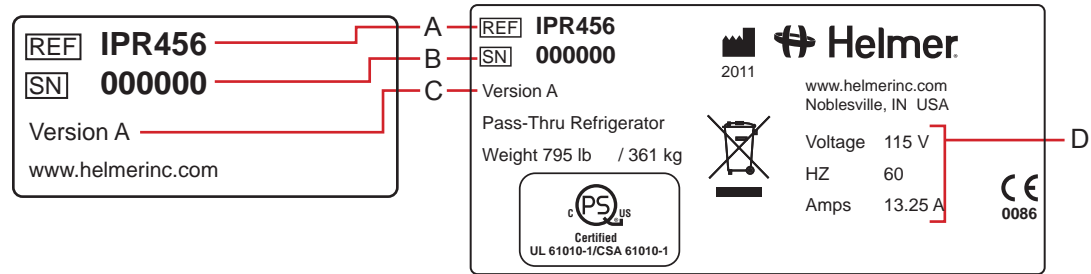

Left: Chamber label. Right: Product Specification label.

Label	Description
A	Model (REF)
B	Serial number
C	Version
D	Power requirements

3.2 Identifying the control system

Service information varies depending on the control system. Helmer refrigerators have one of two control systems installed. The type of control system varies by model.

Model group	Control system
iB, iPR	i.C ³ monitoring and control system
HB, HPR	Horizon Series monitoring and control system

3.2.1 i.C³ control system

i.Series refrigerators are equipped with the i.C³ monitoring and control system. The i.C³ system combines temperature control and monitoring into a single interface, displaying multiple information logs with historical information in full color. The touchscreen monitor, located on the refrigerator door, displays operational information. The chamber temperature controller is integrated into the i.C³ system.



i.C³ monitoring and control system display.

3.2.2 Horizon Series control system

Horizon Series refrigerators feature the Horizon combined monitor and temperature controller. The Horizon Series system controls chamber temperature and monitors and displays operational information. The user interface for this system is located over the refrigerator door.



Horizon Series monitoring and control system display.

3.3 Preparing temperature probes

Temperature probes monitor chamber temperature. Number and location of probes varies by model.

In addition to using standard probes installed by Helmer, external probes may be introduced through existing top ports and immersed in existing probe bottles. Probes can also be inserted through a side access port (availability varies by model).

For each probe bottle, obtain:

- ▶ Approximately 4 oz (120 ml) of product simulation solution. Solution is a 10:1 ratio of water to glycerin.



Left: Probe bottle with temperature and chart recorder probes. Middle: Access port as seen from the top of the refrigerator. Right: Access port on side of refrigerator. The number and location of ports varies by model.

To install an additional external probe through the side

- 1 Remove the interior and exterior plugs to expose the side access port and insert third-party probe through port into chamber.
- 3 Insert probe into bottle.
- 4 Replace plugs, ensuring a tight seal.

To fill a temperature probe bottle

**CAUTION**

- ▶ Clean bottle first, as required.
 - ▶ Temperature probes are fragile; handle with care.
-

- 1 Remove all probes from bottle.
- 2 Remove bottle from bracket and fill with approximately 4 oz (120 ml) of product simulation solution.
- 3 Cap tightly to minimize evaporation.
- 4 Place bottle in bracket and replace probes, immersing at least 2 inches (50 mm) in solution.

3.4 Preparing the chart recorder

If installed, see the Temperature Chart Recorder Operation and Service Manual on CD.

Complete these tasks to prepare recorder for use:

- ▶ Installing the backup battery
- ▶ Adding paper
- ▶ Calibrating the chart recorder to match the upper chamber temperature.

3.4.1 i.Series chart recorder access

For iB and iPR models, open the door by pressing and releasing it.



i.Series chart recorder access.

3.4.2 Horizon Series chart recorder access

For HB and HPR models, pull the door open.



Horizon Series chart recorder access.

3.4.3 Changing chart paper

One piece of chart paper records temperatures continuously for seven days. For additional information on changing the chart paper, see the Temperature Chart Recorder Operation and Service Manual on CD.

Section II: i.Series™ Models

This page left blank intentionally.

4 Product Configuration

4.1 Installing batteries for backup power

The monitoring systems and chart recorder each have a battery backup system, enabling a period of continuous operation if power is lost.

NOTE The monitoring systems will start on battery power alone. If the refrigerator was previously not connected to AC power and the backup battery is connected or switched on, the monitoring system will begin running on battery power.

Battery life varies by manufacturer as well as voltage level remaining. Providing full power is available, and no battery-related alarms are active, backup power for the i.C³ monitoring system is available for up to 20 hours (the Low Battery alarm will activate after approximately 18 hours of battery use). Backup power for the temperature chart recorder is available for up to 14 hours.

NOTE If AC power is lost, the i.C³ monitoring system will automatically disable some features to prolong backup battery power. Data collection functions will continue until backup battery power is depleted.



CAUTION

- ▶ Before installing or replacing batteries, disconnect power to the refrigerator.
- ▶ When installing a replacement battery for the monitoring system, use only a battery which meets the specifications outlined in chapter 6.6 (Supplies).

The battery holder is located on the top of the refrigerator behind the front bezel.

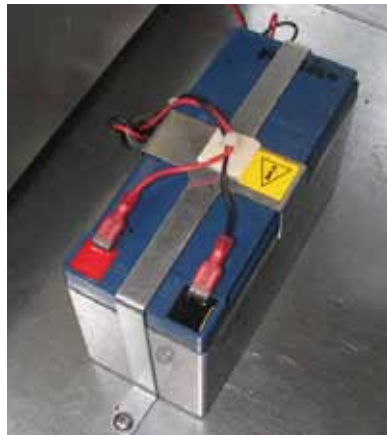

Monitoring system backup battery.

Models	Monitoring system	Battery requirements
iB and iPR	Combined alarm monitoring and control system	One rechargeable 12 V lead acid sealed battery

The rechargeable backup battery is switched off for shipping. Switch the battery ON to provide the monitoring system with backup power in the event of a main power failure.

4.2 Refrigerator setpoint configuration

The temperature controller adjusts chamber temperature around the refrigerator setpoint. The controller activates the compressor when the chamber probe registers temperature above the setpoint.

The controller also senses unit cooler temperature through a probe in the cooler. The temperature in the unit cooler typically varies from the temperature in the chamber, so an offset value is used in the control system. The unit cooler temperature combined with the offset value establishes the refrigerator setpoint.

NOTE The probes in the bottles are connected to the monitoring system and sense chamber temperature. These probes do not impact the refrigerator setpoint.

4.2.1 Determining current refrigerator setpoint

First, confirm:

- ▶ Refrigerator has run for at least 24 hours to stabilize chamber temperature.
- ▶ Chamber temperature is not fluctuating because of excessive door openings and closings.
- ▶ Refrigerator has been placed per location requirements. See Operation manual.
- ▶ Preventive maintenance has been completed. See Operation manual.
- ▶ Troubleshooting items associated with chamber temperature have been reviewed.

Obtain:

- ▶ An independent thermometer, calibrated and traceable per national standards.
 - ▶ Tape. This is used to secure the probe to the thermometer.
- 1 Remove all probes from the upper probe bottle.
 - 2 Unscrew the cap from the bottle.
 - 3 Tape the independent thermometer to the temperature probe, and replace them in the bottle so their ends are immersed at least 2 inches (50 mm).
 - 4 On the independent thermometer, monitor temperature for about 10 minutes to determine an approximate range.
 - 5 From the range, calculate an approximate average temperature. This is the current setpoint.
 - 6 Remove thermometer and probe from the bottle and remove tape.
 - 7 Replace bottle cap, ensuring a tight fit.
 - 8 Place probes in bottle, immersing at least 2 inches (50 mm).

4.2.2 Changing refrigerator setpoint

The default setpoint is 4.0 °C.

Change the setpoint if:

- ▶ Your organization requires a chamber temperature different from 4.0 °C.
- ▶ The normal chamber temperature is too high or low, even after completing preventive maintenance and applicable troubleshooting tasks.

Before changing setpoint, confirm:

- ▶ Refrigerator has been placed per location requirements. See Operation manual.
- ▶ Preventive maintenance has been completed. See Operation manual.
- ▶ Troubleshooting items associated with chamber temperature have been reviewed.

The temperature controller is integrated into the i.C³ monitoring and control system. The temperature setpoint is configured through the i.C³ screen.

**CAUTION**

Do not change setpoint to a value outside the temperature control range.

- 1 Determine the new setpoint temperature.
- 2 Determine the change in value to reach the desired setpoint. The adjustment should be about half of the difference between the current setpoint and the new setpoint. For example, if the desired normal temperature is 4.0 °C, but the current setpoint is 4.5 °C, then the difference is -0.5 °C, and the setpoint adjustment value would be approximately -0.3 °C.
- 3 On the i.C³ screen, touch **i.C³ APPS, i.C³ Settings**. Enter the Settings password then touch **Temperature Setpoints**.

NOTE

The Settings screen may be password protected. A valid four-digit password must be entered to view settings. If viewing settings for the first time, enter the factory default password of “1234”.

- 4 Touch plus (+) or minus (-) on the **Temperature Setpoint** spin box until the correct value appears. The button increments are ± 0.1 °C.
- 5 The setpoint is changed. Touch **Home** to return to the home screen.

4.5

External monitoring devices

**CAUTION**

Do not connect any monitoring device that exceeds the maximum load capacity for your model.

The refrigerator provides a remote alarm interface to send information to external devices, such as the Helmer Remote Alarm Monitoring System. For more information and availability, contact Helmer or your local distributor.

The remote alarm interface is a relay switch with three terminals: Common (COM), Normally Open (NO), and Normally Closed (NC). These terminals are dry contacts and do not supply voltage. The interface circuit is either normally open or normally closed depending on which terminals are used.

The requirements for your alarm system determine which wires must connect to which terminals.

To connect to the remote alarm interface

- 1 Switch the AC ON/OFF switch OFF.
- 2 Switch the battery backup switch OFF.
- 3 On the electrical box, locate the remote alarm interface.
- 4 Connect the remote alarm wires to the appropriate terminals according to the requirements for your alarm system.
- 5 Using a cable tie, secure the wires together for stability (as needed).
- 6 Switch the battery backup switch ON.
- 7 Switch the AC ON/OFF switch ON.

4.6 Moving drawers, shelves, and baskets

Not all containers are available for all models.



Storage features (availability of shelves, drawers, and baskets varies by model).



CAUTION

- ▶ Before moving drawers, shelves, baskets, slides or brackets, protect stored items from extended exposure to adverse temperatures.
- ▶ Before moving drawers, be sure they are completely empty for safe lifting.

To remove a drawer or basket

- 1 Pull the drawer or basket all the way out until it stops.
- 2 On the right rail, locate the release tab and press it downward.
- 3 While holding the right release tab downward, locate the release tab on the left rail and press it upward.
- 4 Pull the drawer or basket free of the slides.

To install a drawer or basket

- 1 Align the end guides on the drawer or basket with the slides.
- 2 Gently push the drawer or basket into the chamber until it stops.
- 3 To ensure proper installation, pull drawer or basket back out until it stops, then push it back in again.

To remove a shelf

- 1 With one hand, lift the front edge of the shelf from the front brackets.
- 2 With the other hand, reach under the shelf and gently bump the rear edge of the shelf upward to disengage it from the rear brackets.

To install a shelf

- 1 Insert the shelf into the chamber, placing it on the brackets.
- 2 Gently bump the rear edge of the shelf downward to engage it with the rear brackets.
- 3 Test installation by pulling the shelf forward gently. The shelf should not disengage from rear brackets.

4.6.1 Drawer labels

Drawers feature a label groove (labels not provided).



Drawer with sample label.

4.6.2 Moving slides and brackets

To remove a set of slides

- 1 Using a screwdriver, remove the retainers for the front brackets.
- 2 Tap the front brackets upward to disengage them from the standard.
- 3 Remove the slide from the standards.

To install a set of slides

- 1 Insert the slides into the appropriate height in the standard.
- 2 Tap the front brackets downward to engage them in the standards.
- 3 Using a screwdriver, install the retainers for the front brackets.

To remove a set of shelf brackets

- 1 Using a screwdriver, remove the retainers for the front brackets.
- 2 Tap the front brackets upward to disengage them from the standards.
- 3 Remove the front brackets from the standards.

To install a set of shelf brackets

- 1 Insert the front brackets into the appropriate height in the standards.
- 2 Tap the front brackets downward to engage them in the standards.
- 3 Using a screwdriver, install the retainers for the front brackets.

4.6.3 Drawer weight

NOTE Maximum drawer load is 100 lbs (46 kg).

4.7 Door characteristics

Some service information varies with respect to door characteristics. Depending on model, a refrigerator may have two or four doors, and pads may be installed on the door handles. Options include solid, glass, and heated glass doors. Single-door models may have hinges on the right or left side. Double-door models are always left- and right-hinged on both sides.

The monitoring and control system interface is located on the door.

NOTE Doors are not field-reversible for any pass-thru refrigerator model.

Model group	Door handle pads
Blood Bank (iB) Pharmacy / Laboratory (iPR)	Pads included

Model group	Door type
Blood Bank (iB) Pharmacy / Laboratory (iPR)	Glass, heated glass, or solid

Number of doors	Hinge location
Two-door models (225)	Right hinge or left hinge. Two door models are factory-reversible.
Four-door models (456)	Left door has left hinge, right door has right hinge. Four door models are not factory or field-reversible.

4.7.1 Optional adapter kits for medication dispensing locks

Call Helmer or your distributor for specific system information.

4.8 Connecting to the internal outlet

If installed, this duplex outlet, with vapor-proof cover and a GFCI (ground fault circuit interrupter), provides a power source for operating devices inside refrigerator.



Internal duplex outlet.



CAUTION

- ▶ The internal outlet is rated for 115 V, 15 A. Do not plug any device into these outlets that exceeds this rating.
- ▶ Test the GFCI periodically to ensure proper, safe operation.

5 Temperature Controller Programs



Left: Temperature Controller Programs screen. Right: Temperature Calibration screen.

Settings

The i.C³ temperature monitor and controller is programmed at the factory with the settings that are listed in this chapter. To change the value for a setting, first enter the Settings mode for that setting. The method for accessing the Settings mode for each setting varies.

NOTE The Settings screen may be password protected. A valid four-digit password must be entered to view settings. If viewing settings for the first time, enter the factory default password of “1234”.

Hysteresis

The hysteresis band (range) value for i.Series pass-thru refrigerator models is factory preset according to model and cabinet size. This value represents each side of the refrigerator setpoint value, for a combined total band (range). This value should not be changed.



CAUTION Changing temperature settings affects the operation of the refrigerator. Do not change settings unless instructed to do so in product documentation or by a Helmer Technical Services representative.

5.1 Temperature setpoint settings

NOTE When there is no interaction for two minutes, the Temperature Setpoint screen closes and returns to the home screen.



CAUTION The hysteresis setpoint is factory-preset and should not be changed unless directed by Helmer Technical Service.

- 1 Touch **i.C³ APPS**, **i.C³ Settings**. Enter the Settings password then touch **Temperature Setpoints**.
- 2 Touch plus (+) or minus (-) on the **Temperature Setpoint** spin box.
 - ▶ The setpoint is the temperature at which the refrigerator operates.
- 3 Touch plus (+) or minus (-) on the **Hysteresis Setpoint** spin box.
 - ▶ The hysteresis setpoint is the allowable fluctuation in temperature, relative to the temperature setpoint. A lower hysteresis setpoint will limit the temperature variation to a smaller range; a higher setpoint will allow the temperature to vary across a larger range.

- 4 Touch plus (+) or minus (-) on the **Delay on Start-Up** spin box.
 - ▶ The refrigerator compressor startup is delayed to allow the i.C³ monitoring and control system to start first.
- 5 Touch plus (+) or minus (-) on the **Duty Cycle of Control Relay during Probe Error** spin box.
 - ▶ The duty cycle is the percentage of time the compressor will run in the event of a temperature control probe failure.

Setting	Setting description	Initial factory setting
Temperature Setpoint	Temperature at which the refrigerator operates	4 °C
Hysteresis Setpoint	Allowable temperature fluctuation, relative to the temperature setpoint	Varies according to model and cabinet size
Delay on Start-Up	Time (in minutes) that a compressor start will be delayed after a power interruption	2 minutes
Duty Cycle of Control Relay during Probe Error	Percentage of time the compressor will run during a probe error	10%

5.2 Temperature calibration settings

NOTE When there is no interaction for two minutes, the Temperature Calibration screen closes and returns to the home screen.



CAUTION The Control Sensor and Control Sensor Offset, Evaporator Defrost and Evaporator Defrost Offset, and Compressor Probe Temperature settings are factory-preset and should not be changed unless directed by Helmer Technical Service.

- 1 Touch **Home, i.C³ APPS, Settings**.
- 2 Enter the Settings password.
- 3 Touch **Temperature Calibration**.
- 4 Touch plus (+) or minus (-) on the **Control Sensor** spin box.
 - ▶ The value for the probe should match the temperature measured in the unit cooler (at the control sensor) by an independent thermometer, calibrated and traceable per national standards.
- 5 Touch plus (+) or minus (-) on the **Control Sensor Offset** spin box.
 - ▶ The value for the offset should be equal to the difference between the refrigerator setpoint and the temperature as measured by an independent thermometer (at the upper probe bottle).
 - ▶ Raise the offset value to lower chamber temperature; lower the offset value to raise chamber temperature.
 - ▶ Example: (measured temperature at the upper probe bottle) – (refrigerator setpoint) = (offset value)
 - ▶ Example: 4.5 – 4.0 = 0.5
- 6 Touch plus (+) or minus (-) on the **Upper Temperature** spin box.
 - ▶ The value for the probe should match the temperature measured in the upper probe bottle by an independent thermometer.
- 7 Touch plus (+) or minus (-) on the **Lower Temperature** spin box.
 - ▶ The value for the probe should match the temperature measured in the lower probe bottle by an independent thermometer.

- 8 Touch plus (+) or minus (-) on the **Evaporator Defrost** spin box.
- ▶ The value should match the temperature measured in the unit cooler (at the defrost coil sensor) by an independent thermometer.
- 9 The Evaporator Defrost Offset value is set at the factory and should not be changed unless directed by Helmer Technical Service.

Setting	Setting description	Default value
Control Sensor	Calibrated temperature of the temperature control sensor (measured at the evaporator).	Varies (set at the factory to match independent calibrated thermometer)
Control Sensor Offset	Adjustment value used if the refrigerator setpoint is not equal to the temperature measured by an independent thermometer.	Varies (set at the factory; difference between setpoint and temperature measured at the control sensor)
Upper Temperature	Calibrated temperature for the upper chamber probe.	4.0 °C
Lower Temperature	Calibrated temperature for the lower chamber probe.	4.0 °C
Evaporator Defrost	Calibrated temperature for the evaporator defrost probe (measured at the evaporator defrost heater).	Varies (set at the factory to match independent calibrated thermometer)
Evaporator Defrost Offset	Adjustment value used by the factory to limit the maximum evaporator defrost temperature.	Varies (set at the factory)
Compressor Probe Temperature	Calibrated temperature for the compressor probe (measured at the condenser).	Varies (set at the factory to match independent calibrated thermometer)

6 Maintenance

**CAUTION**

See operation manual for the preventive maintenance (PM) schedule.

6.1 Recharging refrigerant

**CAUTION**

The procedures in this chapter should only be completed by trained refrigeration technicians who are familiar with the terminology and processes described here, as well as with local and organizational regulations regarding refrigerant leaks.

Use only non-CFC R-134A refrigerant.

The amount of the full initial charge varies by model and power requirements, which can be found on the product specification label.

The initial charge is:

Model	Power requirements	Initial charge
Two-door models (225)	115 V, 60 Hz	16.0 oz (454 g)
Four-door models (456)	115 V, 60 Hz	20.0 oz (567 g)

Obtain:

- ▶ Refrigerant of the appropriate type and quantity
 - ▶ A calibrated pressure gauge capable of reading 0 lb/in² to 25 lb/in² (0 kPa to 175 kPa)
- 1 Attach the pressure gauge to the refrigeration lines.
 - 2 Monitor the low side (suction) pressure through a full compressor cycle.
 - 3 At the end of the next cycle, before the compressor stops, measure the pressure. The pressure varies depending on the ambient air temperature. The low side pressure should be 16 lb/in² to 18 lb/in² (110 kPa to 125 kPa).
 - 4 Add refrigerant so the pressure is within the acceptable range.

6.2 Checking the monitoring system backup battery

**CAUTION**

Checking the monitoring system rechargeable backup battery requires that power be disconnected from the refrigerator, which may affect the chamber temperature. Before testing the alarm, take precautions to protect items in the refrigerator from extended exposure to adverse temperatures.

The monitoring system has a visual indicator to indicate that the monitoring system is running on rechargeable battery power. On all i.C³ screens, the Battery icon will appear in the header bar when the system is running on battery power and the screen brightness will automatically be reduced. The monitoring system will automatically disable some features to extend battery life.

Regularly test whether the backup battery is functioning, and replace it if the test fails or if the battery has been in use for two years.

Test whether the backup battery is functioning

- 1 Disconnect the refrigerator from AC power by disconnecting the AC power cord from the wall outlet or by switching the AC ON/OFF switch OFF. The display should continue to display information with the screen backlight at reduced brightness. The battery icon will appear in the header bar of the screen. If the display is blank, replace the battery.
- 2 Re-connect the refrigerator to AC power.

**CAUTION**

When installing a replacement battery for the monitoring system, use only a battery which meets the specifications outlined in chapter 6.6 (Supplies).

6.3 Replacing LED lamps

Depending on the refrigerator configuration, the refrigerator is shipped with one or two LED lamp strips installed. Replacement LEDs are available from Helmer.

**CAUTION**

- ▶ Follow all chemical handling and disposal requirements and procedures specified by your organization. See chapter 2 (Safety).
- ▶ Replacing lamps requires power disconnection. Protect items in the refrigerator from extended exposure to adverse temperatures.

- 1 Disconnect the power.
- 2 Using a screwdriver, detach the lamp strip from the chamber.
- 3 Unsnap the defective LED from the strip and disconnect the wires.
- 4 Snap new LED on to the lamp strip.
- 5 Reconnect the wires.
- 6 Reattach the lamp strip to the chamber.
- 7 Connect power to refrigerator and test the new lamp.

6.4 Cleaning the refrigerator

Condenser grill



CAUTION

- ▶ Disconnect power to the refrigerator to eliminate the potential of electric shock and injury from surrounding components.
 - ▶ Cleaning the condenser grill requires power disconnection. Protect items in the refrigerator from extended exposure to adverse temperatures.
-

The condenser grill is the finned surface at the rear of the unit. It must be kept clean for proper operation. Not cleaning condenser grill regularly significantly reduces refrigerator life expectancy. In environments where the refrigerator is exposed to excessive lint or dust, condenser grill may need to be cleaned more frequently than stated on the PM schedule.

Clean the condenser grill using a soft brush and a vacuum cleaner.

Exterior

Clean glass surfaces with a soft cotton cloth and glass cleaner. Clean other exterior surfaces with a soft cotton cloth and a non-abrasive liquid cleaner.



CAUTION

The condensate evaporator and the water evaporation tray are hot.

Interior

Clean painted surfaces with mild detergent. Clean stainless steel surfaces with a general-purpose laboratory cleaner suitable for stainless steel.

Door gaskets

Clean door gaskets with a soft cloth and mild soap and water solution.

Clean and refill probe bottles

NOTE A replacement kit that includes a probe bottle and glycerin is also available from Helmer.



CAUTION Protect stored items from extended exposure to adverse temperatures.

Obtain:

- ▶ Fresh water-bleach solution (not provided) Solution is a 10% bleach solution (1 part bleach to 9 parts water, where bleach means a 5% solution of commercial sodium hypochlorite (NaOCl)). Otherwise, use an equivalent oxidizing cleaner/disinfectant approved for use by your organization.
- ▶ Approximately 4 oz (120 ml) of product simulation solution per bottle. Solution is a 10:1 ratio of water to glycerin.



CAUTION Temperature probes are fragile. Handle with care.

- 1 Remove all probes from bottle.
- 2 Remove bottle from bracket and clean with water-bleach solution.
- 3 Fill with approximately 4 oz (120 ml) of product simulation solution.
- 4 Cap tightly to minimize evaporation.
- 5 Place bottle in bracket and replace probes, immersing at least 2 inches (50 mm) in solution.

i.C³ touchscreen

Clean the touchscreen with a soft, dry cotton cloth.

6.5

Removing and installing the unit cooler cover

The unit cooler cover has a port to drain condensation generated in the cooling process. If the unit cooler cover is not removed correctly, the drain port may be damaged. Improper drainage may result in excessive icing in the refrigerator and the refrigerator's inability to maintain the temperature setpoint.

This drain port fits into a piece of vinyl tubing that directs the condensate into the evaporation tray enclosed below the refrigerator cabinet. Before removing the unit cooler cover, first remove the vinyl tubing.

The following is required to remove and reinstall the unit cooler cover:

- ▶ 5/16" socket wrench
- ▶ Tool to push putty away from the tubing

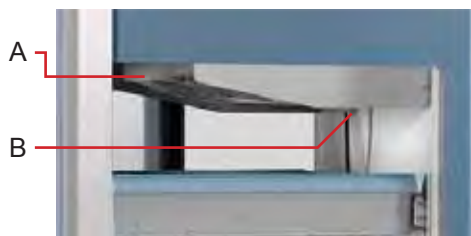

Unit cooler features. Unit cooler (A) inside the chamber, with drain port (B).

To remove the unit cooler cover

- 1 In the lower front control panel, switch the AC ON/OFF switch OFF. Disconnect the refrigerator from outlet power as well. Switch the battery backup switch OFF.
- 2 Peel the putty back to expose the vinyl tube inside the chamber. The putty may be hardened from exposure to cold temperature; allow enough time for the putty to soften.
- 3 Remove the vinyl tube from the unit cooler drain port (B) by pulling it downward to separate it from the unit cooler. Twisting the tube somewhat makes it easier to pull. The drain port on the unit cooler should now be visible.
- 4 Push the excess slack in the drain tube aside.
- 5 Remove the top drawer, basket, or shelf from the chamber.
- 6 While holding the unit cooler cover in place to prevent it from dropping, use the socket wrench to remove the four screws securing the cover to the unit cooler. Gently lower the cover to avoid damaging the unit cooler fan wiring.

To reinstall the unit cooler cover

- 1 In the chamber, verify the wiring for the unit cooler fan is connected and routed correctly. The wiring should be routed above the copper tube inside the unit cooler. If the wires have separated, reconnect them (the two wires marked with wire ties should be connected to each other).
- 2 Reinstall the unit cooler fan cover. Lift the unit cooler cover into place, making sure the front of the cover is behind the lip on the unit cooler. Using the socket wrench, tighten the screws to secure the cover in place. Make sure the screws are tight enough so the unit cooler does not move when bumped. If the unit cooler is not tightly in place, the tubing will be more difficult to install.
- 3 Pull the vinyl drain tube upward at an angle so the end slides over the drain port. The drain port should be completely covered by the tube.
- 4 Return the refrigerator to normal operation. Connect the refrigerator to outlet power then switch the AC ON/OFF switch ON. Switch the backup battery ON and cancel the alarm by touching the **Mute** button.

6.6 Supplies

Refrigerant: non-CFC, R-134A

Chart paper: 220366, 52 sheets

Glycerin solution: 400922-1

LED lamp: 400954-1, ≈ 1.3 W

NOTE Number of LEDs will vary depending on refrigerator model.

Monitoring system backup battery

One 12 V, 7 Ah rechargeable sealed lead acid battery: 120628

Chart recorder backup battery

One 9 V non-rechargeable alkaline (or equivalent) battery: 120218

7 Troubleshooting



CAUTION

Review all safety instructions prior to completing troubleshooting recommendations. See chapter 2 (Safety).

7.1 General operation problems

Problem	Possible Cause	Action
A drawer or basket does not slide easily.	A drawer slide is faulty.	▶ Confirm the slide is operating correctly. Replace if necessary.
	There is debris in the drawer slides.	▶ Pull the drawer or basket out and confirm the slides are free of debris. Clean the slides if necessary.
	The drawer slides are not lubricated.	▶ Using a lightweight oil, lubricate the bearings in the slides.
	The drawer or basket is misaligned or not level.	▶ Confirm both slides for the drawer or basket are mounted at the same height.
A door does not open easily.	There is debris in the hinges.	▶ Confirm the hinges are free of debris. Clean the hinges if necessary.
	The door hinges are not lubricated.	▶ Using a general-purpose grease, lubricate the pivots in the hinges.
	A hinge cam is faulty.	▶ Confirm the hinge cam is not damaged. Replace the cam if necessary.
The monitor display is hard to read.	The screen brightness is set too low.	▶ Change the screen brightness.
The alarm monitor is not responding.	Digital electronics are locked because of an interruption in power.	▶ Reset the monitoring system.
The chamber temperature meets an alarm condition, but the appropriate temperature alarm is not active.	The temperature alarm setpoint was changed.	▶ Check the current setpoints for the temperature alarms. Change the setpoints if necessary.
The chamber temperature displayed is higher or lower than the actual temperature.	The probe bottles are empty, or the amount of solution is too low.	▶ Check the level of product simulation solution in the bottles. Refill the bottles if necessary.
	The monitor is not calibrated.	▶ Confirm the upper temperature probe is reading correctly. Calibrate the probe if necessary.
	Digital electronics are locked because of an interruption in power.	▶ Reset the monitoring system.
	A component is faulty or internal connections are loose.	▶ Contact Helmer Technical Service.

Problem	Possible Cause	Action
The chamber temperature does not stabilize at the refrigerator setpoint.	The condenser grill is dirty.	▶ Check the condenser grill. Clean the grill if necessary.
	The air circulation at the top of the chamber is not adequate.	▶ Check if there are any items that may obstruct air flow and remove them if necessary.
	The ambient air temperature around the refrigerator is too high.	▶ Confirm the refrigerator is placed appropriately.
	The refrigerant level is too low.	▶ Check refrigeration lines for leaks and repair if necessary. Check the refrigerant level. Recharge refrigerant if necessary.
	A component is faulty or internal connections are loose.	▶ Contact Helmer Technical Service.

7.2 Chamber temperature problems

Problem	Possible Cause	Action
The chamber temperature displayed is higher or lower than the actual temperature.	The connections for the chamber temperature probe are loose.	▶ Test the probe connections. Secure the connections if necessary.
	The temperature probe wiring is an open circuit.	▶ Check the continuity of the probe wiring. Replace the probe if necessary.
	The probe bottles are empty, or the amount of solution is too low.	▶ Check the level of product simulation solution in the bottles. Refill the bottles if necessary. See the Refrigerator Operation Manual.
The chamber temperature does not stabilize at the refrigerator setpoint.	The compressor starting relay is faulty.	▶ Confirm the relay is operating correctly. Replace the relay if necessary.
	The temperature monitor/controller board is faulty.	▶ Confirm the temperature monitor/controller board is operating correctly. Replace the board if necessary.
	The condensing unit fan is not running.	▶ Check the condensing unit fan connections. Replace the fan motor if necessary.
	The unit cooler fan is not running.	▶ Check the voltage to the fan when door switch is activated. Replace the fan motor or door switch if necessary.
	The compressor motor has seized.	▶ Replace the compressor.
	The temperature control probe is out of calibration.	▶ Confirm the probe is providing accurate temperature readings.
	The temperature control probe is faulty.	▶ Confirm the probe is providing resistance in the range of 98 Ω to 110 Ω. Replace the probe if necessary.
	The refrigerant level is too low.	▶ Check the refrigeration lines for leaks and repair them if necessary. Check the refrigerant level. Recharge the refrigerant if necessary.

Problem	Possible Cause	Action
The compressor runs continuously.	The refrigerator setpoint is set too low.	► Confirm the setpoint is set within the operating range and change it if necessary.
	The temperature control probe is out of calibration.	► Confirm the probe is providing accurate temperature readings.
	The temperature control probe is faulty.	► Confirm the probe is providing resistance in the range of 98 Ω to 110 Ω . Replace the probe if necessary.
	The temperature monitor/controller board is faulty.	► Confirm the temperature monitor/controller board is operating correctly. Replace the board if necessary.
	The compressor starting relay is faulty.	► Confirm the relay is operating correctly. Replace the relay if necessary.
	The temperature monitor/controller board is faulty.	► Confirm the temperature monitor/controller board is operating correctly. Replace the board if necessary.

7.3

Alarm activation problems

Problem	Possible Cause	Action
The refrigerator is in an alarm condition, but alarms are not audible.	The alarm system is faulty.	► Confirm the monitor/controller board and line connections are functioning correctly. Replace the board if necessary.
	The temperature monitor/controller board is faulty.	► Confirm the temperature monitor/controller board is operating correctly. Replace the board if necessary.
	The alarm speaker (HPR models) is faulty.	► Replace the speaker.
	Audible alarms have been muted.	► Verify audible alarms are not muted. Touch the Mute button repeatedly until the Mute timer indicates no time delay.
	A component is faulty or internal connections are loose.	► Contact Helmer Technical Service.
The refrigerator meets an alarm condition, but the appropriate alarm is not active.	The temperature monitor/controller board is faulty.	► Confirm the temperature monitor/controller board is operating correctly. Replace the board if necessary.
	The alarm setpoint was changed.	► Check the current setpoints for the alarms. Change the setpoints if necessary.
	A component is faulty or internal connections are loose.	► Contact Helmer Technical Service.

Problem	Possible Cause	Action
The High Temperature alarm activates when the door is opened, then clears shortly after the door is closed.	The connections for the chamber temperature probe are loose.	▶ Test the probe connections. Secure the connections if necessary.
	The chamber temperature probe is faulty.	▶ Test the probe. Replace the probe if necessary.
	The unit cooler fan continues to run while the door is open.	▶ Test the door switch and unit cooler fan connections. Secure the connections if necessary. Replace the door switch or fan motor if necessary.
	The probe bottles are empty.	▶ Check level of product simulation solution in the bottles. Refill bottles if needed.
	The high temperature alarm setpoint is set too low.	▶ Check the setpoint. Change the setpoint if necessary.
	A component is faulty or internal connections are loose.	▶ Contact Helmer Technical Service.
The refrigerator is connected to power, but the AC Power Failure alarm is active.	The outlet connection is faulty.	▶ Verify power at the outlet. Repair the original outlet or connect to a different outlet if necessary.
	The power cord is faulty.	▶ Confirm the power cord is connected securely. Secure the power cord if necessary.
	The power supply board is faulty.	▶ Replace the power supply board or the temperature control transformer.
	The circuit breaker was tripped (230 V models).	▶ Confirm the circuit breaker is seated. Push the circuit breaker to reset it if necessary.
	A component is faulty or internal connections are loose.	▶ Contact Helmer Technical Service.
The Door Open alarm is activating sporadically.	The doors are not closing completely.	▶ Confirm the hinge cams are not damaged. Replace the cams if necessary.
	The doors are closing but not sealing completely.	▶ Confirm the door gasket seals completely. Replace the door gasket if necessary.
	The connections for the door switch are faulty.	▶ Test the switch connections. Secure the connections if necessary.
	One or both door switches are faulty.	▶ Replace the door switch or switches.
	The temperature monitor/controller board is faulty.	▶ Confirm the temperature monitor/controller board is operating correctly. Replace the board if necessary.
All alarms are activating sporadically.	The alarm system is faulty.	▶ Confirm the monitor/controller board and line connections are functioning correctly. Replace the board if necessary.
	The temperature monitor/controller board is faulty.	▶ Confirm the temperature monitor/controller board is operating correctly. Replace the board if necessary.
	A component is faulty or internal connections are loose.	▶ Contact Helmer Technical Service.

Problem	Possible Cause	Action
The condenser alarm is active.	The refrigerant level is too low.	▶ Check refrigeration lines for leaks and repair if necessary. Check the refrigerant level. Recharge refrigerant if necessary.
	The connections for the condenser temperature probe are loose.	▶ Test the probe connections. Secure the connections if necessary.
	The condenser temperature probe is faulty.	▶ Test the probe. Replace the probe if necessary.
	The condenser probe is not calibrated.	▶ Confirm the condenser probe is reading correctly. Calibrate the probe if necessary.
An alarm is activated but the temperature recorded at activation does not match the alarm setpoint.	The temperature monitor is not calibrated.	▶ Confirm the upper temperature probe is reading correctly. Calibrate the probe if necessary.
	The temperature changed slightly around the time of activation.	▶ No action needed.
The No Battery alarm is activating sporadically.	The battery voltage level on the rechargeable backup battery for the monitoring system is low.	▶ Replace the backup battery for the monitoring system.
The condenser alarm is active.	The compressor is overheating due to lack of airflow.	▶ Check the condenser grill. Clean it if necessary. ▶ Confirm the refrigerator is placed appropriately.
	The condenser alarm setpoint is too low.	▶ Confirm the alarm setpoint is set at the appropriate value.
	The refrigerant level is too low.	▶ Check refrigeration lines for leaks and repair if necessary. Check the refrigerant level. Recharge refrigerant if necessary.
	The condenser probe is out of calibration.	▶ Confirm the probe is providing accurate temperature readings.
	The condenser probe is not calibrated.	▶ Confirm the probe is reading correctly. Calibrate the probe if necessary. ▶ Confirm the probe is providing resistance in the range of 98 Ω to 110 Ω. Replace the probe if necessary.
	A component is faulty or internal connections are loose.	▶ Contact Helmer Technical Service.

7.4 Testing problems

Problem	Possible Cause	Action
The automatic temperature tests do not work.	The connections for the upper chamber temperature probe are loose.	▶ Test the probe connections. Secure the connections if necessary.
	The upper chamber probe is out of calibration.	▶ Confirm the probe is providing accurate temperature readings.
	The upper chamber temperature probe is faulty.	▶ Confirm the probe is reading correctly. Calibrate the probe if necessary. ▶ Confirm the probe is providing resistance in the range of 98 Ω to 110 Ω . Replace the probe if necessary.
	The temperature monitor/controller board is faulty.	▶ Confirm the temperature monitor/controller board is operating correctly. Replace the board if necessary.
	The High Alarm setpoint is set significantly higher than the default value, or the Low Alarm setpoint is set significantly lower than the default value.	▶ Confirm the alarm setpoints are set at the appropriate values. ▶ Test the temperature alarms manually.

7.5 Condensation problems

Problem	Possible Cause	Action
There is excessive water in the water evaporation tray.	The heater in the evaporation tray is faulty.	<ul style="list-style-type: none"> ▶ Confirm the heater is hot and is drawing the appropriate current. <ul style="list-style-type: none"> ▶ For 115 V refrigerators, the current should be approximately 0.43 A to 0.55 A ▶ For 230 V refrigerators, the current should be approximately 0.21 A to 0.35 A
	Humid air is entering the chamber.	▶ Confirm the refrigerator is level, and the doors are aligned, closing tightly, and sealing correctly. Correct issues as necessary.
There is excessive water in the chamber.	Humid air is entering the chamber.	▶ Confirm the refrigerator is level, and the doors are aligned, closing tightly, and sealing correctly. Correct issues as necessary.
	The connection between the unit cooler and the drain tube is loose.	▶ Confirm the connection is secure. Tighten the connection if necessary.
	The temperature monitor/controller board is faulty.	▶ Confirm the temperature monitor/controller board is operating correctly. Replace the board if necessary.
	The drain line is plugged.	▶ Confirm the drain tube is free of debris. Remove debris if necessary.
There is excessive humidity on the doors.	Humid air is entering the chamber.	▶ Confirm the refrigerator is level, and the doors are aligned, closing tightly, and sealing correctly. Correct issues as necessary.
	The relative humidity around the refrigerator is too high.	▶ Confirm the refrigerator is placed properly. See the refrigerator Operation Manual.
Water leaks from the bottom of the refrigerator.	Humid air is entering the chamber.	▶ Confirm the refrigerator is level, and the door is aligned, closing tightly, and sealing correctly.
	Excessive water is found in the evaporation tray inside the refrigerator.	▶ Contact Helmer Technical Service to correct issues as necessary.

8 Parts

This chapter concerns replaceable parts and part numbers. It also includes references to schematics, as appropriate. See chapter 9 (Schematics).



CAUTION

Before replacing parts that affect chamber temperature, take precautions to protect items in the refrigerator from extended exposure to adverse temperatures.

8.1 Front (control side)

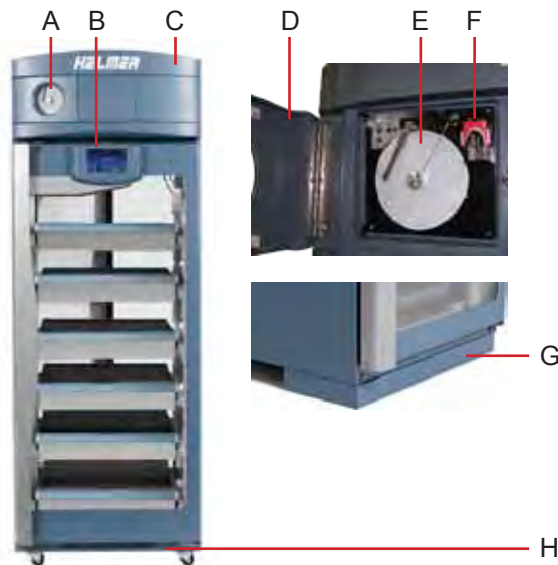

Front features. Left: iB225 refrigerator. Top-right: Chart recorder and door. Bottom-right: Optional skirt.

Label	Description	Replacement part number	Label on schematic
A	Temperature chart recorder (standard on blood bank models; optional on pharmacy/laboratory models)	800026-1	CA
B	i.C ³ monitoring and control system	See subsequent section(s) for part numbers	-
C	Bezel	With chart recorder door: 400999-1 Without chart recorder door: 400998-1	-
D	Chart recorder door assembly (blood bank models)	800070-1	-
E	Chart paper (52 sheets)	220366	-
F	Chart recorder backup battery	120218	CC
G	Skirt (optional, installed on clean room side)	2-door models: 400862-1 4-door models: 400862-1	-
H	Caster (swivel with brake)	220467	-

8.1.1 Control system display parts

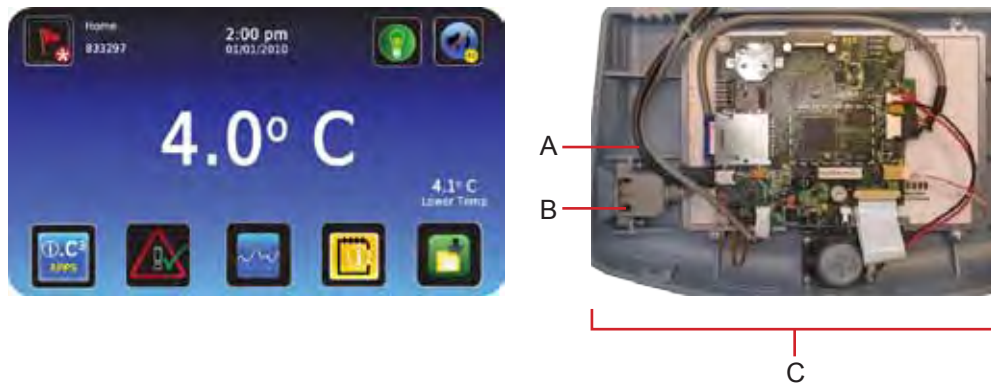

Left: Front view, LCD touchscreen. Right: Rear view of display, showing display board.

Label	Description	Replacement part number	Label on schematic
A	Interface cable	800010-1	IG
B	Power cable	800010-1	IH
C	Display assembly (includes touchscreen, display board, interface cable, speaker)	800041-1	IQ

NOTE Although the touchscreen and display board may be replaced independently of the i.C³ display assembly, Helmer recommends replacing the complete assembly.

8.2 Top



Top features.

Label	Description	Replacement part numbers	Label on schematic
A	Condenser fan motor	225 models: 120467 456 models: 120469	K
B	Compressor	225 models: 400670-1 456 models: 400671-1	J
C	Monitoring system backup battery	120628	IB
D	Power cable	120630	A
Not shown	Cover for clean room side	-	-

8.2.1 Electrical box parts

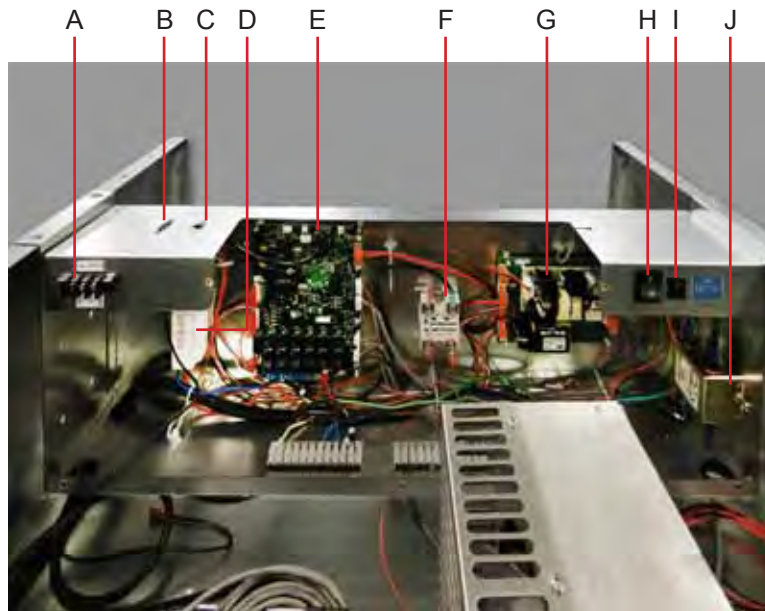

Electrical box features (iPR225 model shown)

Label	Description	Replacement part numbers	Label on schematic
A	Remote alarm contacts	-	-
B	USB port	120633	IE
C	RJ-45 Ethernet port	800008-1	IF
D	Lighting power supply	120624	O
E	Monitor/control board	800034-1	IA
F	Compressor relay	120426	L
G	Power supply board	800035-1	ID
H	Main power switch	120478	C
I	Backup battery switch	120202	IC
J	Power line filter	120400	D
Not shown	RS-232 COM port (optional)	800008-1	

8.3 Bottom

The condensate evaporator is located below the cabinet and is accessed by removing the evaporator cover, on the control side of the refrigerator. This chapter demonstrates the condensate evaporator access panel.

Using a screwdriver, remove the screws holding the condensate evaporator cover and the cover itself.



Condensate evaporator cover.

Label	Description	Replacement part numbers	Label on schematic
Not shown	Condensate evaporator kit (includes condensate evaporator and evaporation tray)	800004-1	G

8.4 Interior



Interior features (iPR456 model shown).

Label	Description	Replacement part numbers	Label on schematic
A	Chart recorder probe	800024-1	CB
B	Upper chamber probe	800048-1	IK
C	Probe bottle and glycerin kit	400922-1	-
D	Lower chamber probe	800037-1	IJ
E	Lamp assemblies	See subsequent section(s) for part numbers.	P
F	Unit cooler	See subsequent section(s) for part numbers.	F
Not shown	Door switch	120380	M
G	Door	See subsequent section(s) for part numbers.	-
H	Storage parts	See subsequent section(s) for part numbers.	-

8.4.1 Light parts



CAUTION

Disconnect refrigerator from power when removing and replacing LED lamps.

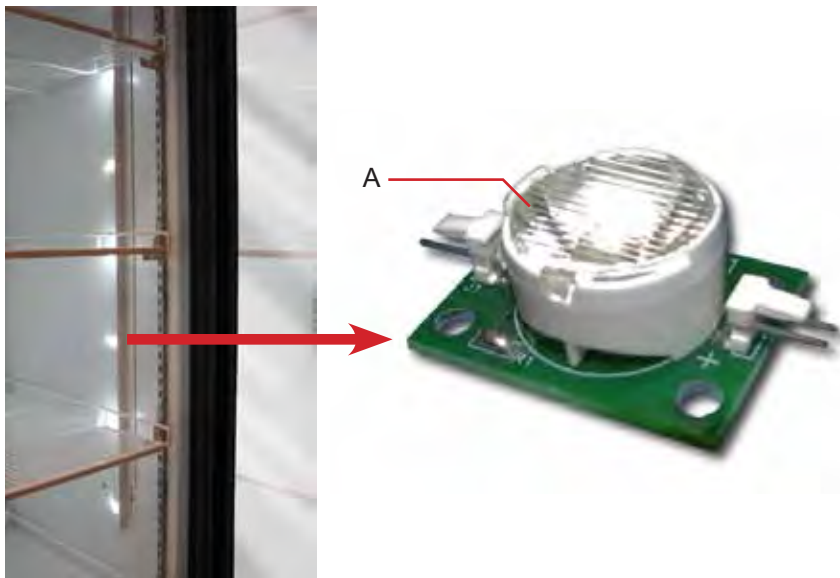

Chamber lights and light parts.

Label	Description	Replacement part numbers	Label on schematic
A	LED lamp	800049-1	P

8.4.2 Unit cooler parts

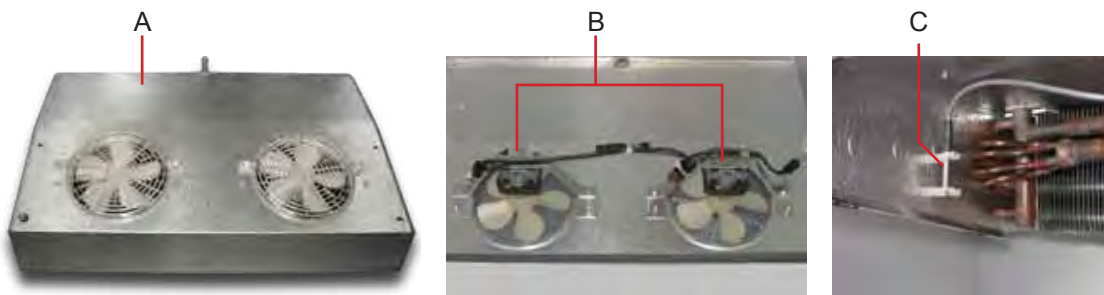

Left: Unit cooler (iB225 model shown). Right: Unit cooler parts.

Label	Description	Replacement part numbers	Label on schematic
A	Unit cooler assembly	225 model (shown): 120594 456 model (three fans): 120595	F
B	Unit cooler fan motor	120540	E
C	Temperature control probe (includes connector)	800048-1	IT

8.4.3 Storage parts



Storage features (iPR456 model shown).

Label	Description	Replacement part numbers
A	Shelf standard	320733-1
B	Shelf	400857-1
C	Two-way drawer assembly (includes drawer with attached slides and hardware)	400856-1
Not shown	Two-way roll-out basket assembly (includes attached slides and hardware)	400858-1
Not shown	Bridge shelf	18" depth: 400845-1 24" depth: 400845-2

8.4.4 Door and hinge parts



Door and hinge features (iPR456 model shown).

Label	Description	Replacement part numbers	Label on schematic
A	Door lock	220540	
B	Door handle pad	320684-1	
C	Upper hinge assembly (includes hinge bearing, hinge pin, and upper hinge bracket)	Left hinge: 400960-2 Right hinge: 400960-1	
D	Door gasket	320726-1	
E	Lower hinge cam	320742-1	
F	Door stop	320763-1	
G	Lower hinge bracket	Right hinge: 400377-1 Left hinge: 400377-2	

9 Schematics

9.1 iB, and iPR models; 225 and 456 configurations

i.Series Refrigerator
iB and iLR
225 and 456 models
Page 1 of 2

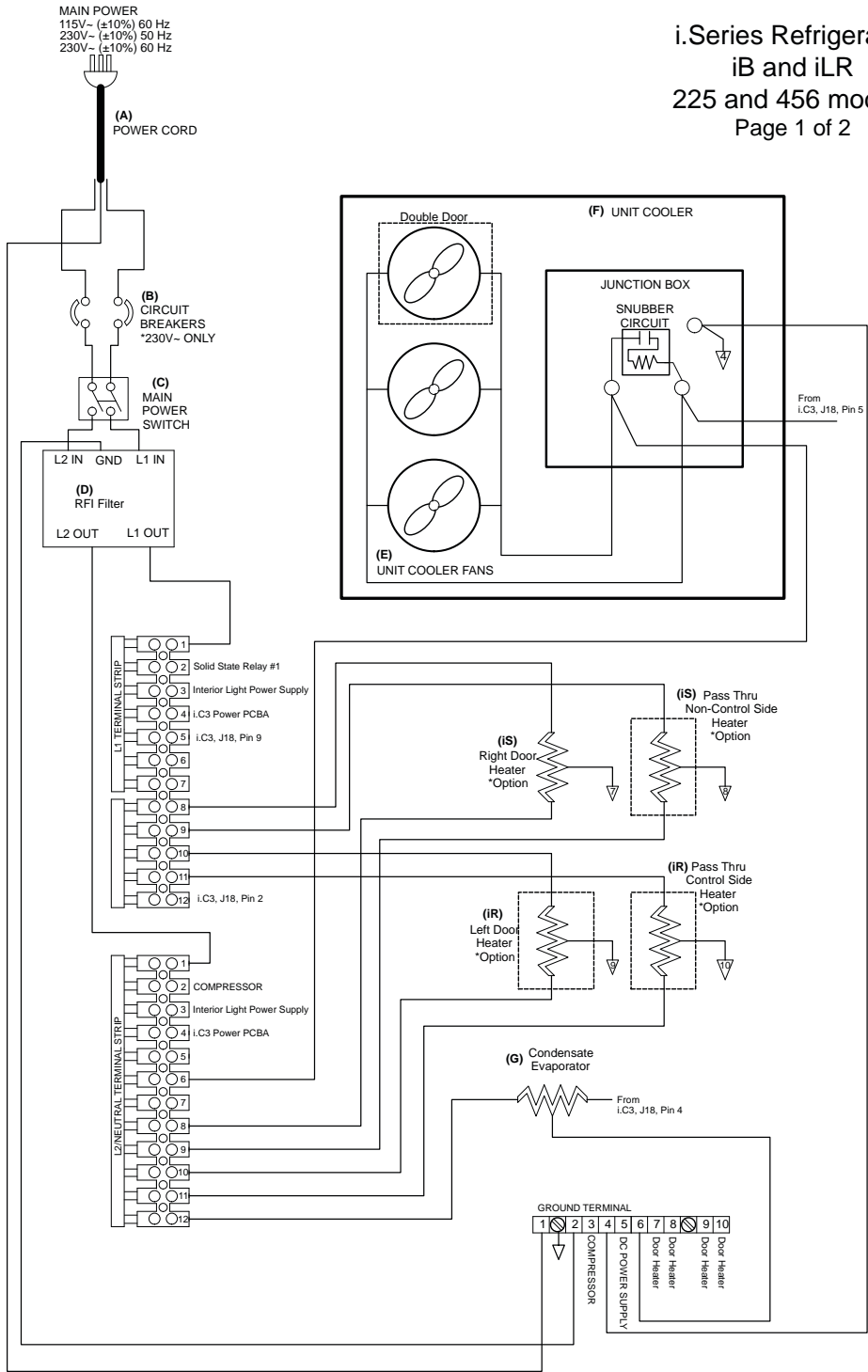

i.Series Refrigerator
iB and iLR
225 and 456 models
Page 2 of 2

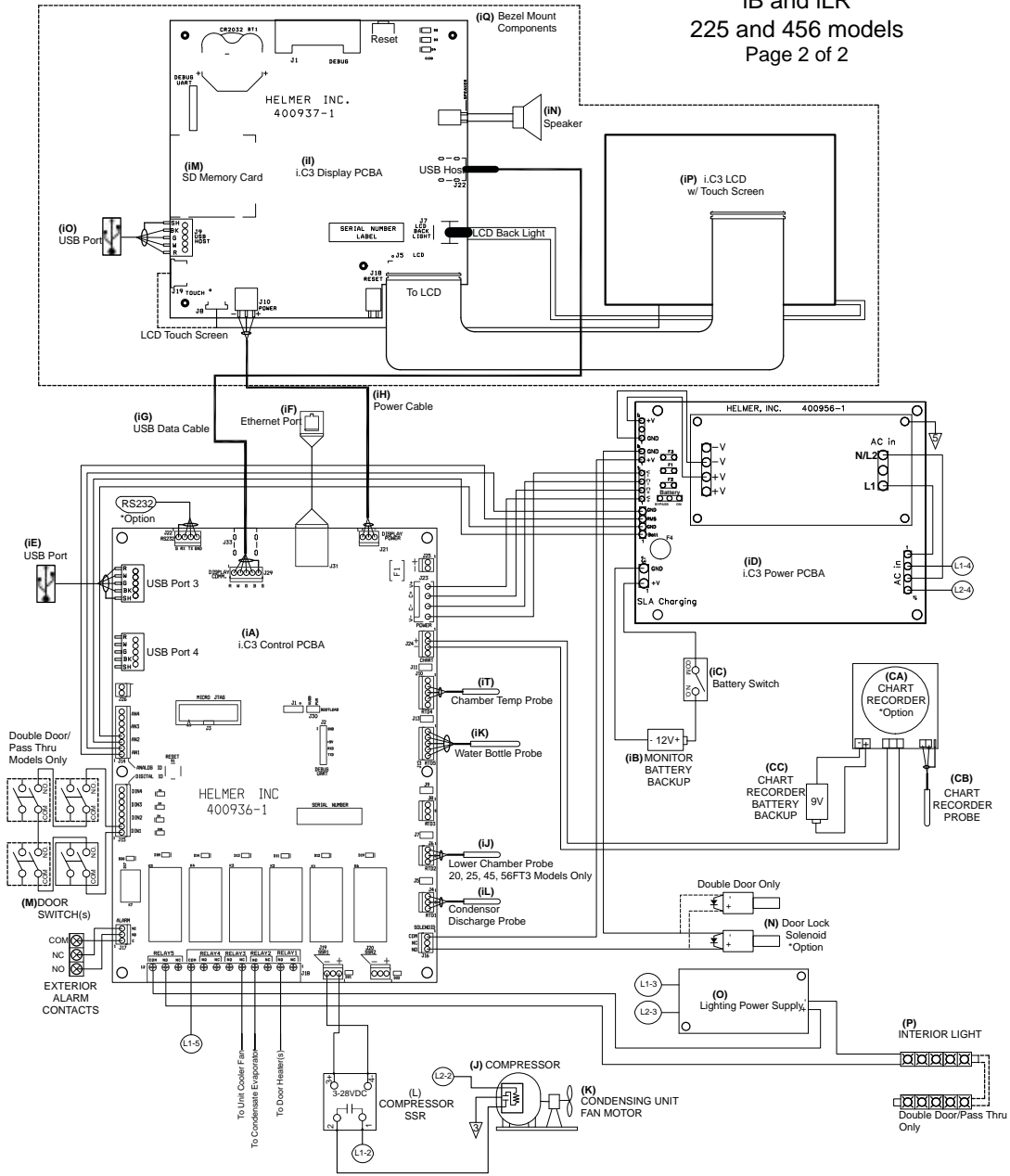

10 Settings

NOTE Information regarding descriptions and default values for general settings, alarm settings, and display settings is available in the i.C³ User Guide.

10.1 Navigating the Home screen

The Home screen displays current information and is the starting screen for all interaction with the monitoring system.

The Home screen appears when:

- ▶ The **Home** button is touched from any other screen
- ▶ There is no interaction for two minutes on any screen other than those used to enter a password



Home screen on the monitoring system.

Label	Description	Function
A	Information header	<ul style="list-style-type: none"> ▶ Allows access to information logs ▶ Indicates new logged alarm events ▶ Provides date, time, and unit ID information ▶ Turn chamber light on or off ▶ Mute active audible alarms
B	Display zone	<ul style="list-style-type: none"> ▶ Identifies active alarm conditions ▶ Displays upper and lower probe temperature ▶ Indicates refrigerator operational status
C	Application icons	<ul style="list-style-type: none"> ▶ Displays customizable i.C³ application button icons

10.1.1 Understanding functions available from the Home screen

NOTE See the i.C³ User Guide for options available on all i.C³ screens.

From the Home screen:

- ▶ View current readings from the temperature probes
- ▶ View the current time and date for the system
- ▶ Access any of the five customizable applications (touch **i.C³ APPS** for additional applications)
- ▶ View detailed information about current or previous alarm events or door open data
- ▶ View whether the monitoring system is running on backup battery power
- ▶ Mute audible alarms
- ▶ Turn the chamber light on and off
- ▶ View a graph of the chamber temperature for the past 24 hours or past 7 days of operation

10.2 Viewing and changing settings

Through the i.C³ monitoring system, the current settings may be viewed and changed. To view settings, touch **Home**, **i.C³ APPS**, **Settings**. Details for each setting are displayed. Use a touch-drag motion to scroll up or down to display additional settings. The settings can be changed through the same screen that they are viewed in. Refer to the i.C³ User Guide for instructions in changing settings, as well as descriptions and default values for each setting.

NOTE The Settings screen may be password protected. A valid four-digit password must be entered to view settings. If viewing settings for the first time, enter the factory default password of “1234”.

10.2.1 Calibrating the settings for the chamber temperature probes

To ensure the high and low temperature alarms are activated properly, the chamber temperature that is read by the temperature probes must be accurate. Verify the probes are reading correctly by comparing the readings to those from an independent thermometer. After determining the appropriate temperature, change the value displayed on the monitor for the temperature probes.

NOTE If the variance is within acceptable limits for your organization, changing the probe settings is optional.

The default setting for the chamber temperature probes is 4.0 °C. The value can be changed to a value from -50.0 °C to +50.0 °C.

Obtain:

- ▶ An independent thermometer, calibrated and traceable per national standards.
- ▶ Tape. This is used to secure the probe to the thermometer.

- 1 Measure the temperature of the upper probe bottle contents.
 - a Remove all probes and the cap from the bottle.
 - b Tape the independent thermometer to the temperature probe, and replace them in the bottle so their ends are immersed at least 2 inches (50 mm) in the solution.
 - c Allow the chamber temperature to stabilize for approximately 10 minutes.
 - d Obtain the reading from the independent thermometer.
- 2 Enter and save the reading from the independent thermometer into the i.C³ system.
 - a From the Home screen, touch, **i.C³ APPS**, **Settings**, **Temperature Calibration**. The Temperature Calibration screen appears.
 - b Touch plus (+) or minus (-) on the **Upper Temperature** spin box to increase or decrease the value to match the measured value.
 - c The message “New Setting Saved” appears next to the spin box, indicating that the new temperature calibration setting is saved.

NOTE Shortly after saving the new temperature value, the displayed temperature may change so it no longer matches the new value. This is normal.

- 3 Replace the probes in the probe bottle.
 - a Remove the thermometer and probe from the bottle and remove the tape from them.
 - b Screw the cap on the bottle, ensuring it fits tightly to minimize evaporation.
 - c Place the probes in the bottle, immersing them at least 2 inches (50 mm) in the solution.

10.2.2 Calibrating the compressor and evaporator probe

To ensure the refrigerator maintains the correct temperature, the compressor and evaporator temperature probes have been calibrated at the factory. Changing the calibration settings for the compressor or evaporator probe is not typically necessary, and should not be performed unless directed to do so by Helmer Technical Service.

10.2.3 Restoring factory defaults

The settings listed below may be simultaneously changed to the factory default value.

This setting	Is restored to this value
Home Screen Application Icons	i.C ³ APPS, Temperature Alarm Test, Temperature Graph, Information Logs, Download
Display Brightness	High (3 symbols)
Password (for Settings screen)	1234
Sounds	On
Alarm Volume	9
Alarm Tone	On
Temperature Calibration Values	Values previously entered during setup
Unit ID	Serial number entered at factory
Date Format	MM/DD/YYYY
Day	Not affected (maintained in real-time clock)
Month	
Year	
Time Format	12-hour
Minute	Not affected (maintained in real-time clock)
Hour	
AM/PM	
Language	Language previously selected during setup
Temperature Units	°C
Password Protection (for Settings screen)	On
Temperature Graph Screensaver	On
Access Control as Home Page	On
Light Off Delay (on/off)	On
Light Off Delay	5 minutes
High Temperature Alarm Setpoint	5.5 °C
High Temperature Alarm Time Delay	0 minutes
Low Temperature Alarm Setpoint *	1.5 °C
Low Temperature Alarm Time Delay	0 minutes
Power Failure Alarm Time Delay	1 minute
Probe Failure Alarm Time Delay	0 minutes
Door Open (Time) Alarm Time Delay	3 minutes
Compressor Temperature Alarm Setpoint	50 °C
Compressor Temperature Alarm Time Delay	0 minutes
Chamber Setpoint	4.0 °C
Chamber Hysteresis	Varies according to model and cabinet size
Delay on Start-Up	2 minutes

Additional defaults for pharmacy and laboratory models

This setting	Is restored to this value
Duty Cycle of Control Relay during Probe Error	50%
Defrost Event #1 On/Off	On
Defrost Event #1 Start Time	12:00 AM
Defrost Event #2 On/Off	On
Defrost Event #2 Start Time	6:00 AM
Defrost Event #3 On/Off	On
Defrost Event #3 Start Time	12:00 PM
Defrost Event #4 On/Off	On
Defrost Event #4 Start Time	6:00 PM
Defrost Time/Defrost Safety Operation Time	20 minutes

* This includes pharmacy/laboratory (iPR) models that were originally set at +2.0 °C.

NOTE Defrost event settings are only applicable to pharmacy/laboratory (iPR) refrigerators.

- 1 Touch **Home, i.C³ APPS, Settings, Restore Factory Settings.**
- 2 A “Are you sure you want to restore factory settings?” message appears. Do one of the following:
 - ▶ To restore the factory default settings, touch the **Yes** button. The message screen closes and the settings are saved.
 - ▶ To cancel restoring factory default settings touch the **No** button. The message screen closes and the settings are not saved.

10.2.4 Changing factory settings

Several of the refrigerator operating parameters are configured at the factory. The settings listed below are set at the factory, and may be changed at the direction of Helmer Technical Service.

Setting	Description
Lower Probe	Toggle the lower temperature probe on or off
Lower Probe Alarm	Toggle the lower temperature probe alarm on or off
Light Icon	Toggle the light icon on or off
Temperature Controller Page	Enable or disable the temperature controller screen

Through the i.C³ monitoring system, the current settings may be viewed and changed. The factory settings can be changed through the same screen that they are viewed in. Contact Helmer Technical Service to verify if changing factory settings is necessary, and for instructions in accessing the factory settings page.

10.3 Testing alarms

Test the alarms to ensure they are working correctly. The refrigerator has alarms that indicate if the chamber temperature becomes too high or too low.

Test these alarms using the built-in Peltier device. The Peltier device physically heats or cools the upper temperature probe; it is unnecessary to insert the probe in chilled or warm water. This automatic method does not affect the chamber temperature.

The alarms may also be tested by placing the upper temperature probe in chilled or warm water and noting the displayed temperature at which the alarm activates.

10.3.1 Testing temperature alarms automatically



NOTE The automatic test can be aborted at any time by touching the **Cancel Test** button.

When performing an automatic low alarm test, the Peltier device cools the probe until the low alarm setpoint is reached. An event is added to the Event Log indicating the low temperature alarm was initiated. The Alarm Test icon is displayed on the Temperature Graph, indicating the change in temperature was test-induced. When completed, the message “Test Complete” appears at the right side of the screen. The test process takes less than five minutes.

When performing an automatic high alarm test, the Peltier device heats the probe until the high alarm setpoint is reached. An event is added to the Event Log indicating the low temperature alarm was initiated. The Alarm Test icon is displayed on the Temperature Graph, indicating the change in temperature was test-induced. When completed, the message “Test Complete” appears at the right side of the screen. The test process takes less than five minutes.

When cancelling an automatic test, the message indicating the test is in progress clears immediately. If a setpoint was reached before the test was cancelled, the alarm activates and clears as described earlier.

To automatically test the low temperature alarm

- 1 Identify the current setting for the low alarm setpoint.
- 2 Touch **Home, i.C³ APPS, Temperature Alarm Test**. The Temperature Alarm Test screen is displayed.
- 3 Touch the **Low Alarm Test** button to start the low alarm test. The button begins to flash.
- 4 In the Alarm Condition area, a “Peltier Test Probe Cooling” message appears.
- 5 When the displayed temperature reaches the alarm setpoint, the temperature reading turns red and an event is added to the Event Log, indicating the low temperature alarm was initiated.
- 6 When completed, the message “Test Complete” appears at the right side of the screen.
- 7 View the Event Log by touching **Home, i.C³ APPS, Information Logs, Event Log**. Touch the event to view the Event Log Detail screen.

-
- 8 Observe the temperature at the time of the low temperature alarm event. Compare this value to the alarm setpoint. If the values do not match, refer to chapter 7 (Troubleshooting) for information on how to proceed.
-

NOTE If the temperature alarm test does not automatically complete within two minutes, restart the i.C³ monitoring system.

To automatically test the high temperature alarm

- 1 Identify the current setting for the high alarm setpoint.
 - 2 Touch **Home, i.C³ APPS, Temperature Alarm Test**. The Temperature Alarm Test screen is displayed.
 - 3 Touch the **High Alarm Test** button to start the high alarm test. The button begins to flash.
 - 4 In the Alarm Condition area, a “Peltier Test Probe Warming” message appears.
 - 5 When the displayed temperature reaches the alarm setpoint, the temperature reading turns red and an event is added to the Event Log, indicating the high temperature alarm was initiated.
 - 6 When completed, the message “Test Complete” appears at the right side of the screen.
 - 7 View the Event Log by touching **Home, i.C³ APPS, Information Logs, Event Log**. Touch the event to view the Event Log Detail screen.
 - 8 Observe the temperature at the time of the high temperature alarm event. Compare this value to the alarm setpoint. If the values do not match, refer to chapter 7 (Troubleshooting) for information on how to proceed.
-

NOTE If the temperature alarm test does not automatically complete within two minutes, restart the i.C³ monitoring system.

To cancel an automatic test in progress

- 1 Touch **Home, i.C³ APPS, Temperature Alarm Test**.
- 2 Touch the **Cancel Test** button. The test is cancelled.

10.3.2 Testing temperature alarms manually



CAUTION The door must be left open during testing, which may affect the chamber temperature. Before testing the alarms manually, take precautions to protect items in the refrigerator from extended exposure to adverse temperatures.

Complete the low alarm test before the high alarm test in order to control the temperature more easily and complete the testing more quickly.

Obtain:

- ▶ An independent thermometer, calibrated and traceable per national standards.
 - ▶ Tape. This is used to secure the probe to the thermometer.
 - ▶ One 8 oz (250 ml) glass half full of chilled water. This holds the water used to measure the temperature.
 - ▶ One glass filled with crushed ice. This is used to cool the water.
 - ▶ One 8 oz (250 ml) glass half full of warm water. This is used to heat the water.
-



CAUTION Temperature probes are fragile. Handle them with care.

- 1 Identify the current settings for the low alarm setpoint and high alarm setpoint.
- 2 Remove the upper chamber temperature probe from the probe bottle.

- 3 Tape the temperature probe to the thermometer, and immerse them in the glass of chilled water so their ends are toward the bottom of the glass.
- 4 Activate the Low Temperature Alarm with this method: While constantly stirring the thermometer and probe in the chilled water and watching the temperature on the monitor, slowly add ice so the temperature decreases 0.5 °C per minute. This is approximately 1 teaspoon (5 ml) of ice every 15 to 25 seconds. Be sure to keep the end of the thermometer and probe in the lower liquid and not in the upper ice. When the temperature reaches the low alarm setpoint, an alarm sounds and the temperature reading turns red. An event is added to the event log indicating the low temperature alarm was started.
- 5 Note the temperature on the independent thermometer when the alarm was triggered.
- 6 Activate the High Temperature Alarm with this method: While constantly stirring the thermometer and probe in the chilled water and watching the temperature on the monitor, slowly add warm water so the temperature increases 0.5 °C per minute. When the temperature reaches the high alarm setpoint, an alarm sounds and the temperature reading turns red. An event is added to the event log indicating the high temperature alarm was started. The test is complete.
- 7 Note the temperature on the independent thermometer when the alarm was triggered.
- 8 Remove the thermometer and probe from the water and remove the tape from them.
- 9 Place the probe in the bottle, immersing it at least 2 inches (50 mm) in the solution.
- 10 Compare each recorded thermometer value to its corresponding setpoint. If the values do not match, see chapter 7 (Troubleshooting) for information on how to proceed.

10.3.3 Testing the power failure alarm



CAUTION

Testing the power failure alarm requires that power be disconnected from the refrigerator, which may affect the chamber temperature. Before testing the alarm, take precautions to protect items in the refrigerator from extended exposure to adverse temperatures.

Test the power failure alarm to ensure it activates at the appropriate time.

During a power failure, the backup battery continues to provide power to the monitoring system.

- 1 Identify the current setting for the Power Failure Time Delay.
- 2 Change the setting to zero minutes. For instructions, refer to the i.C³ User Guide.
- 3 Disconnect the refrigerator from power by switching the AC ON/OFF switch on the electrical box OFF. The power failure alarm should activate immediately, causing the audible alarm to sound and the Power Failure alarm message to appear on the Home screen. An event is added to the event log indicating a power failure alarm condition.
- 4 Power the refrigerator on by switching the AC ON/OFF switch on the electrical box ON. The power failure alarm will clear, causing the audible alarm to clear and the Power Failure alarm message to clear from the Home screen. An event is added to the event log indicating the power failure alarm condition reset.
- 5 Change the Power Failure Time Delay setting back to the original value.

10.3.4 Testing the door open alarm

**CAUTION**

Testing the door open alarm requires the refrigerator door to be left open for an extended period of time, which may affect the chamber temperature. Before testing the alarm, take precautions to protect items in the refrigerator from extended exposure to adverse temperatures.

- 1 Identify the current setting for the Door Open Time delay.
- 2 Change the setting to zero minutes. For instructions, refer to the i.C³ User Guide.
- 3 Open the refrigerator door. The door open alarm should activate immediately, causing the audible alarm to sound and the Door Open alarm message to appear on the Home screen. An event is added to the event log indicating the door open alarm condition started.
- 4 Close the refrigerator door. The door open alarm should clear, causing the audible alarm to clear and the Door Open alarm message to clear from the Home screen. An event is added to the event log indicating the door open alarm condition reset.
- 5 Change the Door Open Time setting back to the original value.

10.4 Upgrading the system firmware

Helmer may occasionally issue updates for the i.C³ firmware. In the case of updated firmware, follow the upgrade instructions included with the firmware update.

10.5 Calibrating the touchscreen

The i.C³ touchscreen has been calibrated at the factory to ensure that when the screen is touched, the desired key touch is selected. If the i.C³ touchscreen or display circuit board is replaced after the refrigerator has been shipped from the factory, the touchscreen must be recalibrated. If the screen must be recalibrated, contact Helmer Technical Service to obtain the calibration file.

Perform the following procedure to calibrate the touchscreen:

- 1 Insert the flash memory device with the calibration program into the USB port on the i.C³ bezel. The flash memory device can be inserted while any screen displayed on the i.C³.
- 2 Wait approximately 15 to 30 seconds for the calibration file to load.
- 3 When the calibration screen appears, remove the flash memory device from the USB port.
- 4 Follow the on-screen instructions, touching the crosshair icons as they appear on the screen.

NOTE

Information regarding descriptions and default values for general settings, alarm settings, and display settings is available in the i.C³ User Guide. For accurate calibration results and to avoid damage to the touchscreen, touch the crosshairs with the eraser end of a pencil.

- 5 After all crosshairs have been touched, the i.C³ will reboot and display the language screen.

NOTE

If the screen was unintentionally touched outside of any of the crosshair icons during calibration, the screen may be recalibrated using the process outlined above.

10.6 Viewing manufacturer and product information

View version information for contacting Helmer.

- 1 From the Home screen, touch **i.C³ APPS, Contact Helmer**.
- 2 The manufacturer contact information appears.
- 3 The software version appears.

11 Warranty

11.1 Rel.i™ Product Warranty USA and Canada

For technical service needs, please contact Helmer at 800-743-5637 or www.helmerinc.com. Be sure to have the model and serial number available.

11.1.1 Rapid resolution

When a warranty issue arises it is our desire to respond quickly and appropriately. The service department at Helmer is there for you. Helmer will oversee the handling of your warranty service from start to finish. Therefore, Helmer must give advance authorization for all service calls and/or parts needs relating to a warranty issue. Any repeat service calls must also be authorized as well. This allows for proper diagnosis and action. Helmer will not be responsible for charges incurred for service calls made by third parties prior to authorization from Helmer. Helmer retains the right to replace any product in lieu of servicing it in the field.

11.1.2 Compressor

For the warranty period listed below, Helmer will supply the refrigeration compressor, if it is determined to be defective, at no charge, including freight. Helmer will not be liable for installation, refrigerant, or miscellaneous charges required to install the compressor beyond the first year of the warranty period.

- ▶ i.Series model compressor warranty period is seven (7) years.

11.1.3 Parts

For a period of two (2) years, Helmer will supply at no charge, including freight, any part that fails due to defects in material or workmanship under normal use, with the exception of expendable items. Expendable items such as glass, filters, light bulbs, and door gaskets are excluded from this warranty coverage.

Inspection of defective parts by Helmer will be final in determining warranty status. Warranty procedures must be followed in all events.

11.1.4 Labor

For a period of one (1) year, Helmer will cover repair labor costs (including travel) and the cost of refrigerant and supplies necessary to perform authorized repairs. Repair service must be performed by an authorized Helmer service agency following the authorization process detailed above. Alternatively, your facility's staff may work with a Helmer technician to make repairs. Labor costs for repairs made by unauthorized service personnel, or without the assistance of a Helmer technician, will be the responsibility of the end user.

11.1.5 Additional warranty information

The time periods set forth above begin two (2) weeks after the original date of shipment from Helmer. Warranty procedures set forth above must be followed in all events.

THERE ARE NO WARRANTIES WHICH EXTEND BEYOND THE DESCRIPTION ON THE FACE HEREOF. THIS WARRANTY IS EXCLUSIVE AND IN LIEU OF ALL OTHER WARRANTIES, EXPRESS OR IMPLIED, INCLUDING WITHOUT LIMITATION ANY WARRANTY OF MERCHANTABILITY OR FITNESS FOR A PARTICULAR PURPOSE. NO WARRANTIES OF MERCHANTABILITY OR FITNESS FOR PARTICULAR PURPOSE SHALL APPLY.

THE LIABILITY, IF ANY, OF HELMER FOR DIRECT DAMAGES WHETHER ARISING FROM A BREACH OF ANY SALES AGREEMENT, BREACH OF WARRANTY, NEGLIGENCE, OR INDEMNITY, STRICT LIABILITY OR OTHER TORT, OR OTHERWISE WITH RESPECT TO THE GOODS OR ANY SERVICES IS LIMITED TO AN AMOUNT NOT TO EXCEED THE PRICE OF THE PARTICULAR GOODS OR SERVICES GIVING RISE TO THE LIABILITY. IN NO EVENT SHALL HELMER BE LIABLE FOR ANY INDIRECT, INCIDENTAL, CONSEQUENTIAL, OR SPECIAL DAMAGES, INCLUDING WITHOUT LIMITATION DAMAGES RELATED TO LOST REVENUES OR PROFITS, OR LOSS OF PRODUCTS.

This warranty does not cover damages caused in transit, during installation by accident, misuse, fire, flood, or acts of God. Further, this warranty will not be valid if Helmer determines that the failure was caused by a lack of performing recommended equipment maintenance (per Helmer manual) or by using the product in a manner other than for its intended use. Installation and calibration are not covered under this warranty agreement.

11.2 Outside of USA and Canada

Consult your local distributor for warranty information.

12 References and Compliance

D.1 Alarm reference

If an alarm condition is met, an alarm activates. Some alarms are visual only, while others are visual and audible. Some alarms are sent through the remote alarm interface.

The table below indicates if an alarm for a particular model is audible (A), visual (V), or sent through the remote alarm interface (R). Messages for visual alarms, if applicable, appear in the table as well.

Alarm	Alarm type
High Temperature	A, V (“High Temperature”), R
Low Temperature	A, V, (“Low Temperature”) R
Compressor Temperature	A, V (“Compressor Temperature”), R
Door Open (Time)	A, V (“Door Open”), R
Power Failure	A, V (“Power Failure”), R
Low Battery	V, R
Probe Failure	A, V (“Probe Failure”), R
No Cellular Service	A, V (“No Cell Service”), R

D.2 Energy conservation and regulatory compliance

This device complies with the requirements of directive 93/42/EEC concerning Medical Devices, as amended by 2007/47/EC.

This product is certified to applicable UL and CSA standards by a NRTL.

Insulation Type: 2

Pollution Degree: 2 (for use in USA and Canada only)

Sound level is less than 70 dB(A).



WEEE compliance

The WEEE (waste electrical and electronic equipment) symbol (right) indicates compliance with European Union Directive WEEE 2002/96/EC and applicable provisions. The directive sets requirements for the labeling and disposal of certain products in affected countries.



When disposing of this product in countries affected by this directive:

- ▶ Do not dispose of this product as unsorted municipal waste.
- ▶ Collect this product separately.
- ▶ Use the collection and return systems available locally.

For more information on the return, recovery, or recycling of this product, contact your local distributor.

This page left blank intentionally.

Section III: Horizon Series™ Models

This page left blank intentionally.

13 Product Configuration

13.1 Installing batteries for backup power

The monitoring systems and chart recorder each have a battery backup system, enabling a period of continuous operation if power is lost.

NOTE The monitoring systems will start on battery power alone. If the refrigerator was previously not connected to AC power and the backup battery is connected or switched on, the monitoring system will begin running on battery power.

Battery life varies by manufacturer as well as voltage level remaining. Providing full power is available, and no battery-related alarms are active, backup power for the monitoring system is available for up to two hours. Backup power for the temperature chart recorder is available for up to 14 hours.



CAUTION

- ▶ Before installing or replacing batteries, disconnect power to the refrigerator.
- ▶ When installing a replacement battery for the monitoring system, use only a battery which meets the specifications outlined in chapter 15.6 (Supplies).

The battery holder is located on the top of the refrigerator, on top of the electrical box.



Monitoring system backup battery.

Models	Monitoring system	Battery requirements
HB and HPR	Combined alarm monitoring and control system	One non-rechargeable 9 V lithium (or equivalent) battery

The battery is taped next to the battery holder. Connect the battery to the battery wires.

13.2 Refrigerator setpoint configuration

The temperature controller adjusts chamber temperature around the refrigerator setpoint. The controller activates the compressor when the chamber probe registers temperature above the setpoint.

The controller also senses unit cooler temperature through a probe in the cooler. The temperature in the unit cooler typically varies from the temperature in the chamber, so an offset value is used in the control system. The unit cooler temperature combined with the offset value establishes the refrigerator setpoint.

NOTE The probes in the bottles are connected to the monitoring system and sense chamber temperature. These probes do not impact the refrigerator setpoint.

13.2.1 Determining current refrigerator setpoint

First, confirm:

- ▶ Refrigerator has run for at least 24 hours to stabilize chamber temperature.
- ▶ Chamber temperature is not fluctuating because of excessive door openings and closings.
- ▶ Refrigerator has been placed per location requirements. See operation manual.
- ▶ Preventive maintenance has been completed. See operation manual.
- ▶ Troubleshooting items associated with chamber temperature have been reviewed.

Obtain:

- ▶ An independent thermometer, calibrated and traceable per national standards.
 - ▶ Tape. This is used to secure the probe to the thermometer.
- 1 Remove all probes from the upper probe bottle.
 - 2 Unscrew the cap from the bottle.
 - 3 Tape the independent thermometer to the temperature probe, and replace them in the bottle so their ends are immersed at least 2 inches (50 mm).
 - 4 On the independent thermometer, monitor temperature for about 10 minutes to determine an approximate range.
 - 5 From the range, calculate an approximate average temperature. This is the current setpoint.
 - 6 Remove thermometer and probe from the bottle and remove tape.
 - 7 Replace bottle cap, ensuring a tight fit.
 - 8 Place probes in bottle, immersing at least 2 inches (50 mm).

13.2.2 Changing refrigerator setpoint

The default setpoint is 4.0 °C.

Change the setpoint if:

- ▶ Your organization requires a chamber temperature different from 4.0 °C.
- ▶ The normal chamber temperature is too high or low, even after completing preventive maintenance and applicable troubleshooting tasks.

Before changing setpoint, confirm:

- ▶ Refrigerator has been placed per location requirements. See operation manual.
- ▶ Preventive maintenance has been completed. See operation manual.
- ▶ Troubleshooting items associated with chamber temperature have been reviewed.



CAUTION Do not change setpoint to a value outside the temperature control range.

- 1 Determine the new setpoint temperature.

- 2 Determine the change in value to reach the desired setpoint. The adjustment will be the difference. For example, if the desired normal temperature is 4.0 °C, but the current setpoint is 4.5 °C, then the difference is -0.5 °C. The setpoint adjustment value is therefore -0.5 °C.
- 3 On the monitoring system, change to Control mode by pressing and releasing the **SEL** button until the CONTROL lamp is lit.
- 4 Press and hold the **SET** button. A reference temperature displays which is typically higher than the chamber temperature.
- 5 While holding the **SET** button, press the **Up Arrow** and **Down Arrow** buttons as needed to enter the adjustment value determined in step 2. The button increments are ± 0.1 °C.
- 6 When finished, release all buttons. The setpoint is changed.
- 7 Return to Monitor mode by pressing and releasing the **SEL** button until the MONITOR lamp is lit

13.3

External monitoring devices

**CAUTION**

Do not connect any monitoring device that exceeds the maximum load capacity for your model.

The refrigerator provides a remote alarm interface to send information to external devices, such as the Helmer Remote Alarm Monitoring System. For more information and availability, contact Helmer or your local distributor.

The remote alarm interface is a relay switch with three terminals: Common (COM), Normally Open (NO), and Normally Closed (NC). These terminals are dry contacts and do not supply voltage. The interface circuit is either normally open or normally closed depending on which terminals are used.

The requirements for your alarm system determine which wires must connect to which terminals.

To connect to the remote alarm interface

- 1 Switch the AC ON/OFF switch OFF.
- 2 Disconnect the backup power to the monitoring system by removing the battery.
- 3 On the electrical box, locate the remote alarm interface.
- 4 Connect the remote alarm wires to the appropriate terminals according to the requirements for your alarm system.
- 5 Using a cable tie, secure the wires together for stability (as needed).
- 6 Reconnect the backup power to the monitoring system by reinstalling the battery.
- 7 Switch the AC ON/OFF switch ON.

13.4 Moving drawers, shelves, and baskets

Not all containers are available for all models.



Storage features (availability of shelves, drawers, and baskets varies by model).



CAUTION

- ▶ Before moving drawers, shelves, baskets, slides or brackets, protect stored items from extended exposure to adverse temperatures.
- ▶ Before moving drawers, be sure they are completely empty for safe lifting.

To remove a drawer or basket

- 1 Pull the drawer or basket all the way out until it stops.
- 2 On the right rail, locate the release tab and press it downward.
- 3 While holding the right release tab downward, locate the release tab on the left rail and press it upward.
- 4 Pull the drawer or basket free of the slides.

To install a drawer or basket

- 1 Align the end guides on the drawer or basket with the slides.
- 2 Gently push the drawer or basket into the chamber until it stops.
- 3 To ensure proper installation, pull drawer or basket back out until it stops, then push it back in again.

To remove a shelf

- 1 With one hand, lift the front edge of the shelf from the front brackets.
- 2 With the other hand, reach under the shelf and gently bump the rear edge of the shelf upward to disengage it from the rear brackets.

To install a shelf

- 1 Insert the shelf into the chamber, placing it on the brackets.
- 2 Gently bump the rear edge of the shelf downward to engage it with the rear brackets.
- 3 Test installation by pulling the shelf forward gently. The shelf should not disengage from rear brackets.

13.4.1 Moving slides and brackets

To remove a set of slides

- 1 Using a screwdriver, remove the retainers for the front brackets.
- 2 Tap the front brackets upward to disengage them from the standard.
- 3 Remove the slide from the standards.

To install a set of slides

- 1 Insert the slides into the appropriate height in the standard.
- 2 Tap the front brackets downward to engage them in the standards.
- 3 Using a screwdriver, install the retainers for the front brackets.

To remove a set of shelf brackets

- 1 Using a screwdriver, remove the retainers for the front brackets.
- 2 Tap the front brackets upward to disengage them from the standards.
- 3 Remove the front brackets from the standards.

To install a set of shelf brackets

- 1 Insert the front brackets into the appropriate height in the standards.
- 2 Tap the front brackets downward to engage them in the standards.
- 3 Using a screwdriver, install the retainers for the front brackets.

13.4.2 Drawer weight

NOTE Maximum drawer load is 100 lbs (46 kg).

13.5 Door characteristics

Some service information varies with respect to door characteristics. Depending on model, a refrigerator may have one or two doors, and pads may be installed on the door handles. Options include solid, glass, and heated glass doors. Single-door models may have hinges on the right or left side.

On Horizon Series refrigerators, the Horizon monitoring and control system is located above the door.

NOTE Doors are not field-reversible for any pass-thru refrigerator model.

Model group	Door handle pads
Horizon Series (HB, HPR)	Pads not available

Model group	Door type
Blood Bank (HB) Pharmacy / Laboratory (HPR)	Glass or heated glass or solid

Number of doors	Hinge location
Two-door models (225)	Right hinge or left hinge
	Two door models are factory-reversible.
Four-door models (456)	Left door has left hinge, right door has right hinge
	Four door models are not factory or field-reversible.

13.5.1 Optional adapter kits for medication dispensing locks

Call Helmer or your distributor for specific system information.

13.6 Connecting to the internal outlet

If installed, this duplex outlet, with vapor-proof cover and a GFCI (ground fault circuit interrupter), provides a power source for operating devices inside refrigerator.



Internal duplex outlet.



CAUTION

- ▶ The internal outlet is rated for 115 V, 15 A. Do not plug any device into these outlets that exceeds this rating.
- ▶ Test the GFCI periodically to ensure proper, safe operation.

14 Temperature Controller Programs

The refrigerator is shipped from the factory with preset temperature setpoints. These setpoints are specific to the refrigerator's intended use. These setpoints may be changed depending on organizational requirements.

NOTE The Control Offset and Control Hysteresis are factory preset and should not be changed.

14.1 Hysteresis

The hysteresis value for Horizon Series refrigerators is factory preset at 1.5. This value represents each side of the refrigerator setpoint value, for a combined total band (range) value of 3.0. This value should not be changed.

14.2 High alarm setpoint

The High Alarm setpoint specifies the activation point of the high temperature alarm. The default setting is +5.5 °C. The setpoint may be changed to a value from -40.0 °C to +40.0 °C.

14.3 Low alarm setpoint

The Low Temp alarm setpoint specifies the activation point of the Low Temperature Alarm. The default setting is +1.5 °C for blood bank models, and +2.0 °C for pharmacy/laboratory models.

14.4 Control temperature offset value

The Control Offset is used to control chamber temperature. This value is factory preset and should not be changed.

14.5 Monitor temperature offset value

If the temperature displayed on the monitor does not match the actual chamber temperature, the setting for the Monitor Offset can be changed so they match. The monitor offset can be changed to a value from -10.0 °C to +10.0 °C.

15 Maintenance

**CAUTION**

See operation manual for the preventive maintenance (PM) schedule.

15.1 Recharging refrigerant

**CAUTION**

The procedures in this chapter should only be completed by trained refrigeration technicians who are familiar with the terminology and processes described here, as well as with local and organizational regulations regarding refrigerant leaks.

Use only non-CFC R-134A refrigerant.

The amount of the full initial charge varies by model and power requirements, which can be found on the Product Specification label.

The initial charge is:

Model	Power requirements	Initial charge
Two-door models (225)	115 V, 60 Hz	16.0 oz (454 g)
Four-door models (456)	115 V, 60 Hz	20.0 oz (567 g)

Obtain:

- ▶ Refrigerant of the appropriate type and quantity
 - ▶ A calibrated pressure gauge capable of reading 0 lb/in² to 25 lb/in² (0 kPa to 175 kPa)
- 1 Attach the pressure gauge to the refrigeration lines.
 - 2 Monitor the low side (suction) pressure through a full compressor cycle.
 - 3 At the end of the next cycle, before the compressor stops, measure the pressure. The pressure varies depending on the ambient air temperature. The low side pressure should be 16 lb/in² to 18 lb/in² (110 kPa to 125 kPa).
 - 4 Add refrigerant so the pressure is within the acceptable range.

15.2 Checking the monitoring system backup battery

**CAUTION**

Checking the monitoring system backup battery requires that power be disconnected from the refrigerator, which may affect the chamber temperature. Before testing the alarm, take precautions to protect items in the refrigerator from extended exposure to adverse temperatures.

The monitoring system does not have visual indicators for the status of the backup battery. Regularly test whether the backup battery is functioning, and replace it if the test fails or if the battery has been in use for one year.

Test whether the backup battery is functioning

- 1 Disconnect the refrigerator from AC power by disconnecting the AC power cord from the wall outlet or by switching the AC ON/OFF switch OFF. The display should continue to display information. If the display is blank, replace the battery.
- 2 Re-connect the refrigerator to AC power.

**CAUTION**

When installing a replacement battery for the monitoring system, use only a battery which meets the specifications outlined in chapter 16.7 (Supplies).

15.3 Replacing LED lamps

Depending on the refrigerator configuration, the refrigerator is shipped with one or two LED lamp strips installed. Replacement LEDs are available from Helmer.

**CAUTION**

- ▶ Follow all chemical handling and disposal requirements and procedures specified by your organization. See chapter 2 (Safety).
- ▶ Replacing lamps requires power disconnection. Protect items in the refrigerator from extended exposure to adverse temperatures.

- 1 Disconnect the power.
- 2 Using a screwdriver, detach the lamp strip from the chamber.
- 3 Unsnap the defective LED from the strip and disconnect the wires.
- 4 Snap new LED on to the lamp strip.
- 5 Reconnect the wires.
- 6 Reattach the lamp strip to the chamber.
- 7 Connect power to refrigerator and test the new lamp.

15.4 Cleaning the refrigerator

Condenser grill



CAUTION

- ▶ Disconnect power to the refrigerator to eliminate the potential of electric shock and injury from surrounding components.
 - ▶ Cleaning the condenser grill requires power disconnection. Protect items in the refrigerator from extended exposure to adverse temperatures.
-

The condenser grill is the finned surface at the rear of the unit. It must be kept clean for proper operation. Not cleaning condenser grill regularly significantly reduces refrigerator life expectancy. In environments where the refrigerator is exposed to excessive lint or dust, condenser grill may need to be cleaned more frequently than stated on the PM schedule.

Clean the condenser grill using a soft brush and a vacuum cleaner.

Exterior

Clean glass surfaces with a soft cotton cloth and glass cleaner. Clean other exterior surfaces with a soft cotton cloth and a non-abrasive liquid cleaner.



CAUTION

The condensate evaporator and the water evaporation tray are hot.

Interior

Clean painted surfaces with mild detergent. Clean stainless steel surfaces with a general-purpose laboratory cleaner suitable for stainless steel.

Door gaskets

Clean door gaskets with a soft cloth and mild soap and water solution.

Clean and refill probe bottles

NOTE A replacement kit that includes a probe bottle and glycerin is also available from Helmer.



CAUTION

- ▶ Removing the temperature probe from the bottle may cause the chamber temperature to fluctuate.
- ▶ Protect stored items from extended exposure to adverse temperatures.

Obtain:

- ▶ Fresh water-bleach solution (not provided) Solution is a 10% bleach solution (1 part bleach to 9 parts water, where bleach means a 5% solution of commercial sodium hypochlorite (NaOCl)). Otherwise, use an equivalent oxidizing cleaner/disinfectant approved for use by your organization.
- ▶ Approximately 4 oz (120 ml) of product simulation solution per bottle. Solution is a 10:1 ratio of water to glycerin.



CAUTION Temperature probes are fragile. Handle with care.

- 1 Remove all probes from bottle.
- 2 Remove bottle from bracket and clean with water-bleach solution.
- 3 Fill with approximately 4 oz (120 ml) of product simulation solution.
- 4 Cap tightly to minimize evaporation.
- 5 Place bottle in bracket and replace probes, immersing at least 2 inches (50 mm) in solution.

15.5

Removing and installing the unit cooler cover

The unit cooler cover has a port to drain condensation generated in the cooling process. If the unit cooler cover is not removed correctly, the drain port may be damaged. Improper drainage may result in excessive icing in the refrigerator and the refrigerator's inability to maintain the temperature setpoint.

This drain port fits into a piece of vinyl tubing that directs the condensate into the evaporation tray enclosed below the refrigerator cabinet. Before removing the unit cooler cover, first remove the vinyl tubing.

The following is required to remove and reinstall the unit cooler cover:

- ▶ 5/16" socket wrench
- ▶ Tool to push putty away from the tubing

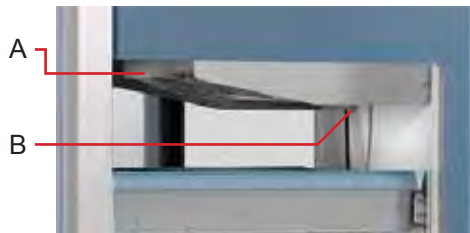

Unit cooler features. Unit cooler (A) inside the chamber, with drain port (B).

To remove the unit cooler cover

- 1 In the lower front control panel, switch the AC ON/OFF switch OFF. Disconnect the refrigerator from outlet power as well. Disconnect the backup battery or turn the Alarm Disable key switch OFF.
- 2 Peel the putty back to expose the vinyl tube inside the chamber. The putty may be hardened from exposure to cold temperature; allow enough time for the putty to soften.
- 3 Remove the vinyl tube from the unit cooler drain port (B) by pulling it downward to separate it from the unit cooler. Twisting the tube somewhat makes it easier to pull. The drain port on the unit cooler should now be visible.
- 4 Push the excess slack in the drain tube aside.
- 5 Remove the top drawer, basket, or shelf from the chamber.
- 6 While holding the unit cooler cover in place to prevent it from dropping, use the socket wrench to remove the four screws securing the cover to the unit cooler. Gently lower the cover to avoid damaging the unit cooler fan wiring.

To reinstall the unit cooler cover

- 1 In the chamber, verify the wiring for the unit cooler fan is connected and routed correctly. The wiring should be routed above the copper tube inside the unit cooler. If the wires have separated, reconnect them (the two wires marked with wire ties should be connected to each other).
- 2 Reinstall the unit cooler fan cover. Lift the unit cooler cover into place, making sure the front of the cover is behind the lip on the unit cooler. Using the socket wrench, tighten the screws to secure the cover in place. Make sure the screws are tight enough so the unit cooler does not move when bumped. If the unit cooler is not tightly in place, the tubing will be more difficult to install.
- 3 Pull the vinyl drain tube upward at an angle so the end slides over the drain port. The drain port should be completely covered by the tube.
- 4 Return the refrigerator to normal operation. Connect the refrigerator to outlet power and turn the AC ON/OFF switch ON. Reconnect the backup battery or turn the Alarm Disable key switch ON.

15.6 Supplies

Refrigerant: non-CFC, R-134A

Chart paper: 220366, 52 sheets

Glycerin solution: 400922-1

LED lamp: 400954-1, ≈ 1.3 W

NOTE Number of LEDs will vary depending on refrigerator model.

Monitoring system backup battery

One 9 V non-rechargeable lithium (or equivalent) battery: 120399

Chart recorder backup battery

One 9 V non-rechargeable alkaline (or equivalent) battery: 120218

16 Troubleshooting



CAUTION

Review all safety instructions prior to completing troubleshooting recommendations. See chapter 2 (Safety).

16.1 General operation problems

Problem	Possible Cause	Action
A drawer or basket does not slide easily.	A drawer slide is faulty.	▶ Confirm the slide is operating correctly. Replace if necessary.
	There is debris in the drawer slides.	▶ Pull the drawer or basket out and confirm the slides are free of debris. Clean the slides if necessary.
	The drawer slides are not lubricated.	▶ Using a lightweight oil, lubricate the bearings in the slides.
	The drawer or basket is misaligned or not level.	▶ Confirm both slides for the drawer or basket are mounted at the same height.
A door does not open easily.	There is debris in the hinges.	▶ Confirm the hinges are free of debris. Clean the hinges if necessary.
	The door hinges are not lubricated.	▶ Using a general-purpose grease, lubricate the pivots in the hinges.
	A hinge cam is faulty.	▶ Confirm the hinge cam is not damaged. Replace the cam if necessary.
The chamber temperature meets an alarm condition, but the appropriate temperature alarm is not active.	The temperature alarm setpoint was changed.	▶ Check the current setpoints for the temperature alarms. Change the setpoints if necessary.
The chamber temperature displayed is higher or lower than the actual temperature.	The probe bottles are empty, or the amount of solution is too low.	▶ Check the level of product simulation solution in the bottles. Refill the bottles if necessary.
	The monitor is not calibrated.	▶ Confirm the upper temperature probe is reading correctly. Calibrate the probe if necessary.
	Digital electronics are locked because of an interruption in power.	▶ Reset the monitoring system.
	A component is faulty or internal connections are loose.	▶ Contact Helmer Technical Service.
“Frob” appears on the display, but the chamber temperature is set correctly.	A component is faulty or internal connections are loose.	▶ Contact Helmer Technical Service.

Problem	Possible Cause	Action
The chamber temperature does not stabilize at the refrigerator setpoint.	The condenser grill is dirty.	▶ Check the condenser grill. Clean the grill if necessary.
	The air circulation at the top of the chamber is not adequate.	▶ Check if there are any items that may obstruct air flow and remove them if necessary.
	The ambient air temperature around the refrigerator is too high.	▶ Confirm the refrigerator is placed appropriately.
	The refrigerant level is too low.	▶ Check refrigeration lines for leaks and repair if necessary. Check the refrigerant level. Recharge refrigerant if necessary.
	A component is faulty or internal connections are loose.	▶ Contact Helmer Technical Service.

16.2 Chamber temperature problems

Problem	Possible Cause	Action
“Prob” appears on the display, but the chamber temperature is set correctly.	The connections for the chamber temperature probe are loose.	▶ Test the probe connections. Secure the connections if necessary.
	The temperature probe wiring is an open circuit.	▶ Check the continuity of the probe wiring and connections. Secure the connections or replace the probe if necessary.
The chamber temperature does not stabilize at the refrigerator setpoint.	The compressor starting relay is faulty.	▶ Confirm the relay is operating correctly. Replace the relay if necessary.
	The temperature monitor/controller board is faulty.	▶ Confirm the temperature monitor/controller board is operating correctly. Replace the board if necessary.
	The condensing unit fan is not running.	▶ Check the condensing unit fan connections. Replace the fan motor if necessary.
	The unit cooler fan is not running.	▶ Check the voltage to the fan when door switch is activated. Replace the fan motor or door switch if necessary.
	The compressor motor has seized.	▶ Replace the compressor.
	The temperature control probe is out of calibration.	▶ Confirm the probe is providing accurate temperature readings.
	The temperature control probe is faulty.	▶ Confirm the probe is providing resistance in the range of 98 Ω to 110 Ω. Replace the probe if necessary.
	The refrigerant level is too low.	▶ Check the refrigeration lines for leaks and repair them if necessary. Check the refrigerant level. Recharge the refrigerant if necessary.

Problem	Possible Cause	Action
The compressor runs continuously.	The refrigerator setpoint is set too low.	▶ Confirm the setpoint is set within the operating range and change it if necessary.
	The temperature control probe is out of calibration.	▶ Confirm the probe is providing accurate temperature readings.
	The temperature control probe is faulty.	▶ Confirm the probe is providing resistance in the range of 98 Ω to 110 Ω . Replace the probe if necessary.
	The temperature monitor/controller board is faulty.	▶ Confirm the temperature monitor/controller board is operating correctly. Replace the board if necessary.
	The compressor starting relay is faulty.	▶ Confirm the relay is operating correctly. Replace the relay if necessary.
	The defrost timer is faulty.	▶ Replace the defrost timer.

16.3

Alarm activation problems

Problem	Possible Cause	Action
The refrigerator is in an alarm condition, but alarms are not audible.	The alarm system is faulty.	▶ Confirm the monitor/controller board and line connections are functioning correctly. Replace the board if necessary.
	The temperature monitor/controller board is faulty.	▶ Confirm the temperature monitor/controller board is operating correctly. Replace the board if necessary.
	The alarm buzzer is faulty.	▶ Replace the alarm buzzer.
	Audible alarms have been muted.	▶ Verify the Alarm Disable key switch is not turned Off.
	A component is faulty or internal connections are loose.	▶ Contact Helmer Technical Service.
The refrigerator meets an alarm condition, but the appropriate alarm is not active.	The temperature monitor/controller board is faulty.	▶ Confirm the temperature monitor/controller board is operating correctly. Replace the board if necessary.
	The alarm setpoint was changed.	▶ Check the current setpoints for the alarms. Change the setpoints if necessary.
	A component is faulty or internal connections are loose.	▶ Contact Helmer Technical Service.

Problem	Possible Cause	Action
The High Temperature alarm activates when the door is opened, then clears shortly after the door is closed.	The connections for the chamber temperature probe are loose.	▶ Test the probe connections. Secure the connections if necessary.
	The chamber temperature probe is faulty.	▶ Test the probe. Replace the probe if necessary.
	The unit cooler fan continues to run while the door is open.	▶ Test the door switch and unit cooler fan connections. Secure the connections if necessary. Replace the door switch or fan motor if necessary.
	The probe bottles are empty.	▶ Check level of product simulation solution in the bottles. Refill bottles if needed.
	The high temperature alarm setpoint is set too low.	▶ Check the setpoint. Change the setpoint if necessary.
	A component is faulty or internal connections are loose.	▶ Contact Helmer Technical Service.
The refrigerator is connected to power, but the AC Power Failure alarm is active.	The outlet connection is faulty.	▶ Verify power at the outlet. Repair the original outlet or connect to a different outlet if necessary.
	The power cord is faulty.	▶ Confirm the power cord is connected securely. Secure the power cord if necessary.
	The temperature control transformer is faulty.	▶ Replace the power supply board or the temperature control transformer.
	The circuit breaker was tripped (230 V models).	▶ Confirm the circuit breaker is seated. Push the circuit breaker to reset it if necessary.
	A component is faulty or internal connections are loose.	▶ Contact Helmer Technical Service.
The Door Open alarm is activating sporadically.	The doors are not closing completely.	▶ Confirm the hinge cams are not damaged. Replace the cams if necessary.
	The doors are closing but not sealing completely.	▶ Confirm the door gasket seals completely. Replace the door gasket if necessary.
	The connections for the door switch are faulty.	▶ Test the switch connections. Secure the connections if necessary.
	One or both door switches are faulty.	▶ Replace the door switch or switches.
	The temperature monitor/controller board is faulty.	▶ Confirm the temperature monitor/controller board is operating correctly. Replace the board if necessary.
All alarms are activating sporadically.	The alarm system is faulty.	▶ Confirm the monitor/controller board and line connections are functioning correctly. Replace the board if necessary.
	The temperature monitor/controller board is faulty.	▶ Confirm the temperature monitor/controller board is operating correctly. Replace the board if necessary.
	A component is faulty or internal connections are loose.	▶ Contact Helmer Technical Service.

Problem	Possible Cause	Action
An alarm is activated but the temperature recorded at activation does not match the alarm setpoint.	The temperature changed slightly around the time of activation.	▶ No action needed.

16.4

Condensation problems

Problem	Possible Cause	Action
There is excessive water in the water evaporation tray.	The heater in the evaporation tray is faulty.	▶ Confirm the heater is hot and is drawing the appropriate current. ▶ For 115 V refrigerators, the current should be approximately 0.43 A to 0.55 A ▶ For 230 V refrigerators, the current should be approximately 0.21 A to 0.35 A
	Humid air is entering the chamber.	▶ Confirm the refrigerator is level, and the doors are aligned, closing tightly, and sealing correctly. Correct issues as necessary.
There is excessive water in the chamber.	Humid air is entering the chamber.	▶ Confirm the refrigerator is level, and the doors are aligned, closing tightly, and sealing correctly. Correct issues as necessary.
	The connection between the unit cooler and the drain tube is loose.	▶ Confirm the connection is secure. Tighten the connection if necessary.
	The defrost timer is faulty.	▶ Replace the defrost timer.
	The drain line is plugged.	▶ Confirm the drain tube is free of debris. Remove debris if necessary.
There is excessive humidity on the doors.	Humid air is entering the chamber.	▶ Confirm the refrigerator is level, and the doors are aligned, closing tightly, and sealing correctly. Correct issues as necessary.
	The relative humidity around the refrigerator is too high.	▶ Confirm the refrigerator is placed properly. See the refrigerator Operation Manual.
Water leaks from the bottom of the refrigerator.	Humid air is entering the chamber.	▶ Confirm the refrigerator is level, and the door is aligned, closing tightly, and sealing correctly.
	Excessive water is found in the evaporation tray inside the refrigerator.	▶ Contact Helmer Technical Service to correct issues as necessary.

17 Parts

This chapter concerns replaceable parts and part numbers. It also includes references to schematics, as appropriate. See chapter 18 (Schematics).



CAUTION

Before replacing parts that affect chamber temperature, take precautions to protect items in the refrigerator from extended exposure to adverse temperatures.

17.1 Front (control side)

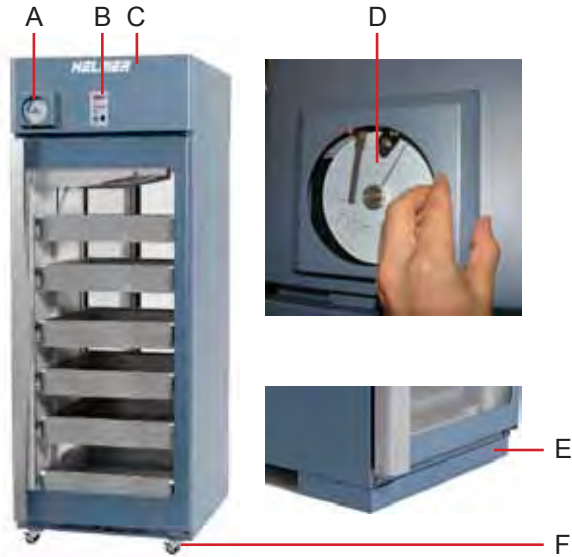

Front features. Left: HB225 refrigerator. Top-right: Chart recorder and door. Bottom-right: Optional skirt.

Label	Description	Replacement part number	Label on schematic
A	Temperature chart recorder (standard on blood bank models; optional on pharmacy/laboratory models)	800026-1	CA
B	Horizon Series monitoring and control system	See subsequent section(s) for part numbers	
C	Bezel	With chart recorder door: 800072-1	-
		Without chart recorder door: 800071-1	-
D	Chart paper (52 sheets)	220366	-
Not shown	Chart recorder backup battery	120218	CC
E	Skirt (optional, installed on clean room side)	2-door models: 400862-1 4-door models: 400862-1	-
F	Caster (swivel with brake)	220467	-

17.1.1 Control system display parts



Left: Front view, Horizon touchpad. Right: Rear view of display, showing monitor/control board.

Label	Description	Replacement part numbers	Label on schematic
A	Touchpad / board assembly	800027-1	HA
B	Light switch	120202	HG
C	Alarm key switch	120227	HD

17.2 Top

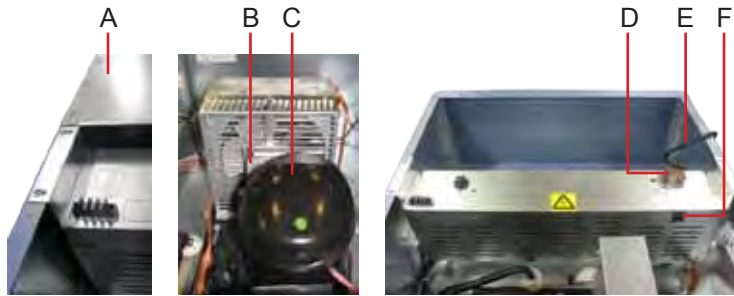

Top features.

Label	Description	Replacement part numbers	Label on schematic
A	Cover for clean room side	-	-
B	Condenser fan motor	225 models: 120467 456 models: 120469	K
C	Compressor	225 models: 400670-1 456 models: 400671-1	J
D	Monitoring system backup battery	120399	HH
E	Power cable	120630	A
F	Main power switch	120478	C

17.2.1 Electrical box parts

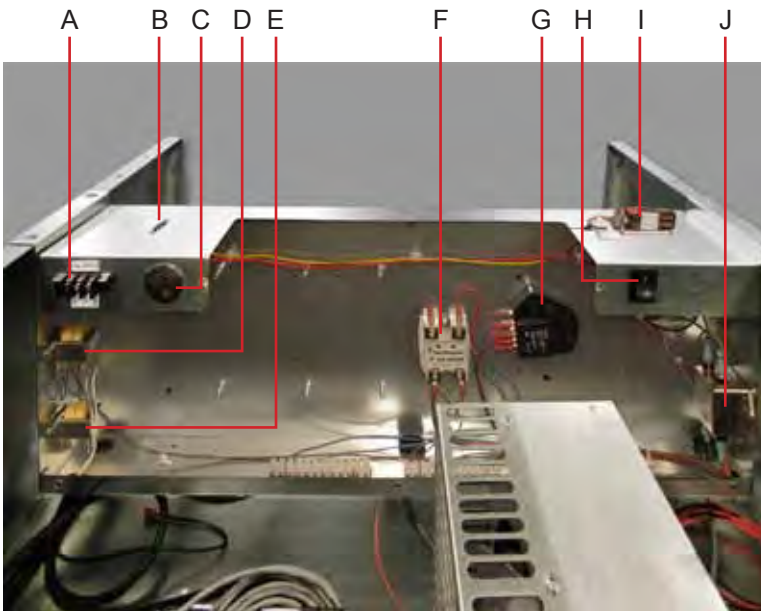

Electrical box features (HPR225 model shown).

Label	Description	Replacement part numbers	Label on schematics
A	Remote alarm contacts	-	-
B	RS-232 COM port	800008-1	-
C	Alarm buzzer	120160	HE
D	Temperature control transformer	800086-1	HO
E	Chart recorder transformer (optional)	-	-
F	Compressor relay	120426	L
G	Defrost timer	800016-1	HF
H	Main power switch	120478	C
I	Monitoring system backup battery	120399	HH
J	Power line filter	120400	D
Not shown	12 V cabinet lighting power supply	120505	O

17.3 Bottom

The condensate evaporator is located below the cabinet and is accessed by removing the evaporator cover, on the control side of the refrigerator. This chapter demonstrates the condensate evaporator access panel.

Using a screwdriver, remove the screws holding the condensate evaporator cover and the cover itself.



Condensate evaporator cover.

Label	Description	Replacement part numbers	Label on schematic
Not shown	Condensate evaporator kit (includes condensate evaporator and evaporation tray)	800004-1	G

17.4 Interior



Interior features (HPR456 model shown).

Label	Description	Replacement part numbers	Label on schematic
A	Upper chamber probe	800029-1	HC
B	Chart recorder probe	800024-1	CB
C	Probe bottle and glycerin kit	400922-1	-
D	Lamp assemblies	See subsequent section(s) for part numbers.	P
E	Unit cooler	See subsequent section(s) for part numbers.	F
F	Door	See subsequent section(s) for part numbers.	-
G	Storage parts	See subsequent section(s) for part numbers.	-
Not shown	Door switch	120380	M

17.4.1 Light parts



CAUTION

Disconnect refrigerator from power when removing and replacing LED lamps.

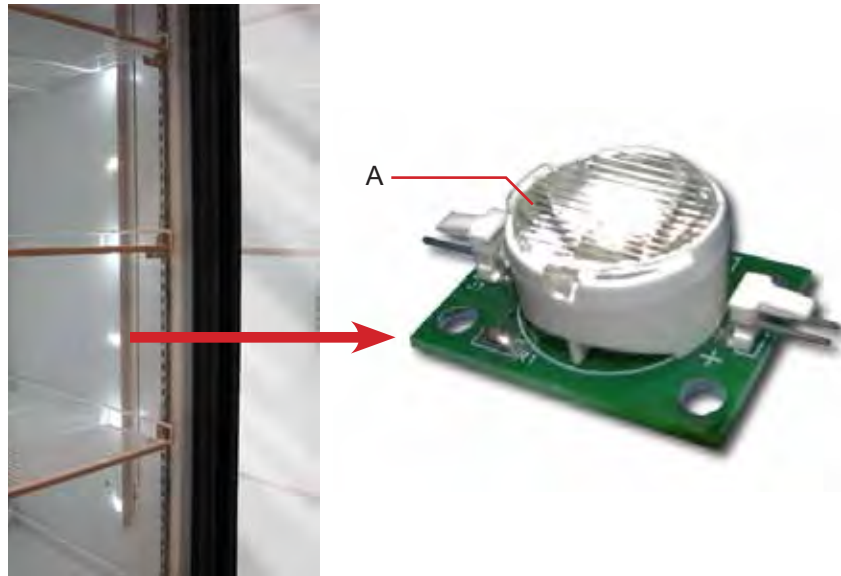

Chamber lights and light parts.

Label	Description	Replacement part numbers	Label on schematic
A	LED lamp	800049-1	P

17.4.2 Unit cooler parts

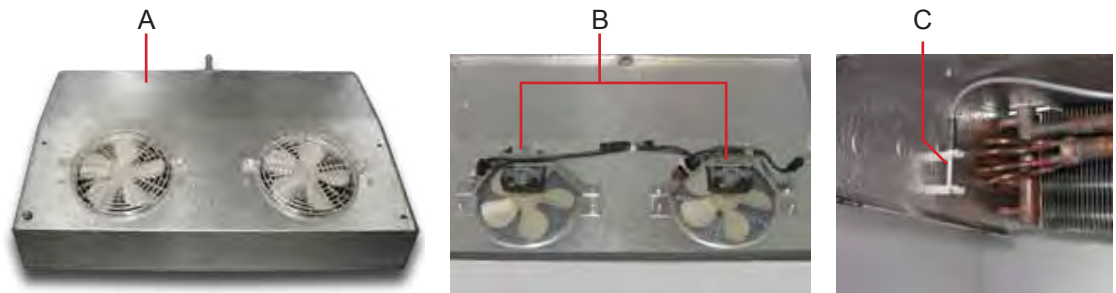

Left: Unit cooler (225 model shown). Right: Unit cooler parts.

Label	Description	Replacement part numbers	Label on schematic
A	Unit cooler assembly	225 model (shown): 120594 456 model (three fans): 120595	F
B	Fan motor	120540	E
C	Temperature control probe	800028-1	HB

17.4.3 Storage parts



Storage parts.

Label	Description	Replacement part numbers
A	Shelf standard	320733-1
B	Shelf	400857-1
C	Two-way drawer assembly (includes drawer with attached slides and hardware)	400856-2
Not shown	Two-way roll-out basket assembly (includes attached slides and hardware)	400858-1

17.4.4 Door and hinge parts



Door and hinge parts.

Label	Description	Replacement part numbers	Label on schematic
A	Door lock	220540	
B	Upper hinge bracket	Left hinge: 400960-2 Right hinge: 400960-1	
C	Upper hinge bearing	220541	-
D	Door gasket	320726-1	
E	Lower hinge cam	320742-1	
F	Door stop	320763-1	
G	Lower hinge bracket	Right hinge: 400377-1 Left hinge: 400377-2	

18 Schematics

18.1 HB and HPR models; 225, and 456 configurations

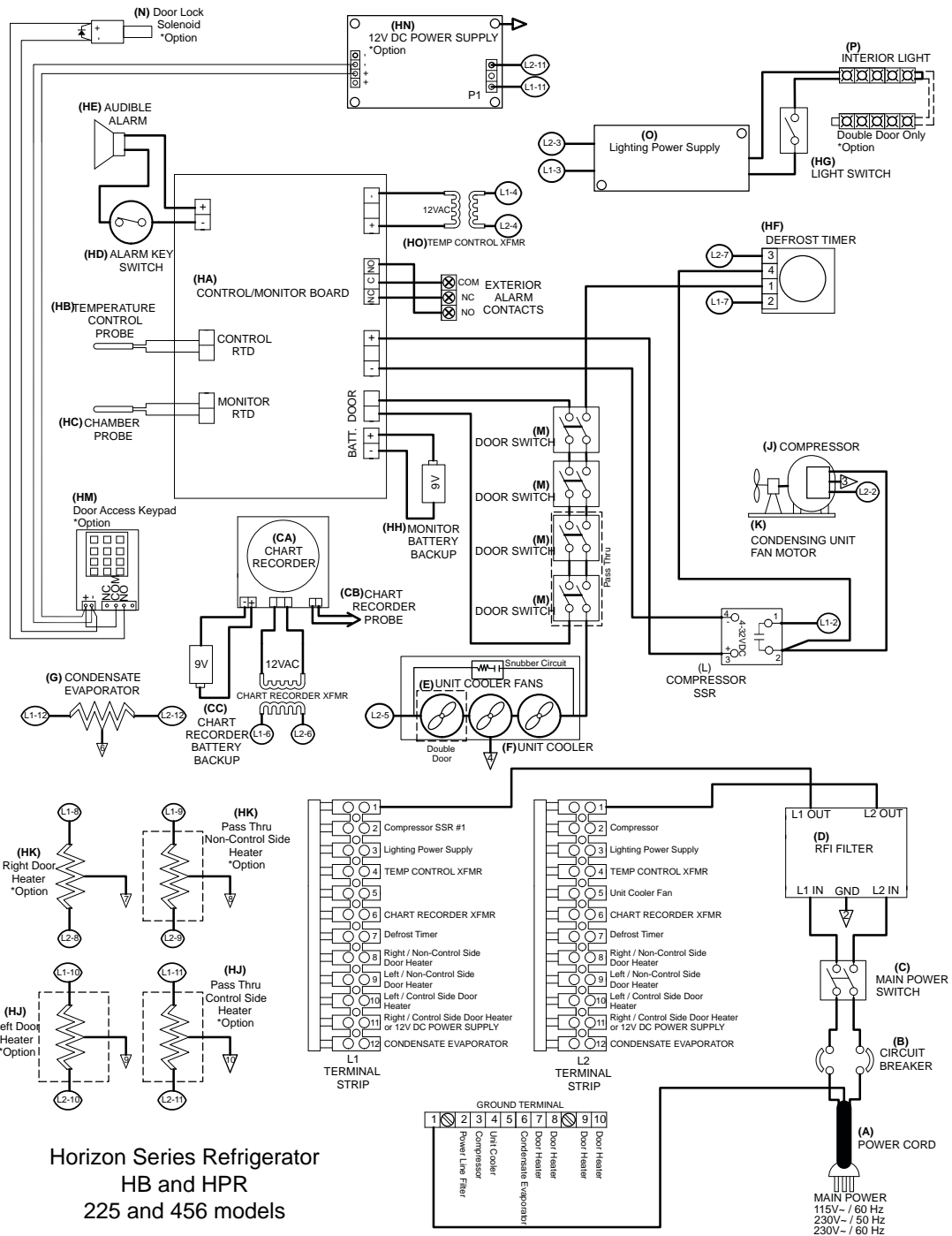

19 Settings

19.1 Touring the monitoring and control system

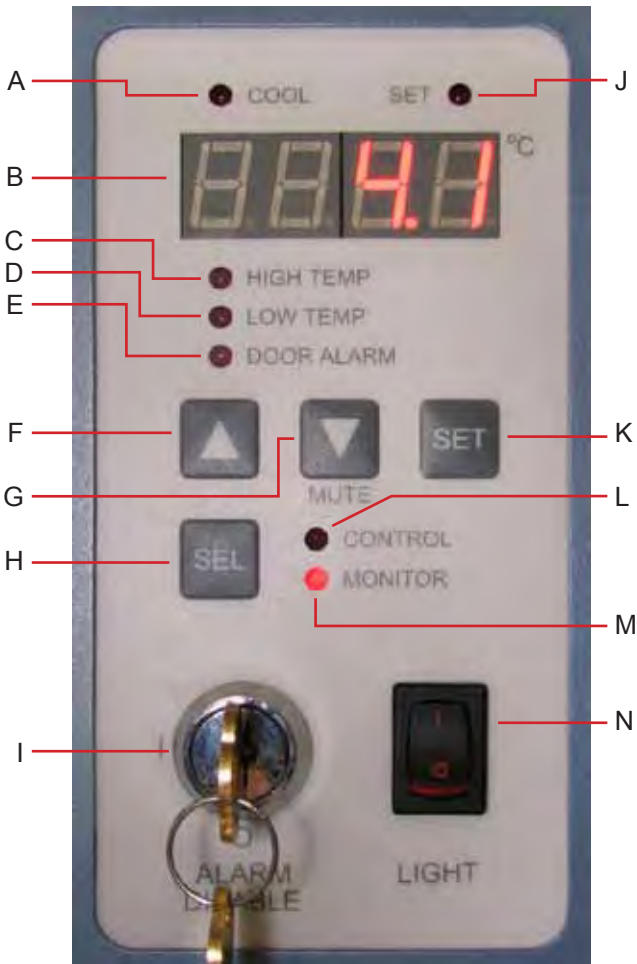

Monitoring and control system for HB and HPR models.

Label	Description	Function
A	COOL lamp	Indicates the compressor is running
B	Display	Displays real-time temperature information, setpoints, and alarms
C	HIGH TEMP lamp	Indicates when the refrigerator is in a high temperature alarm condition. Also indicates the high alarm temperature setpoint is being changed
D	LOW TEMP lamp	Indicates when the refrigerator is in a low temperature alarm condition. Also indicates the low alarm temperature setpoint is being changed
E	DOOR ALARM lamp	Indicates when the door is open for greater than three minutes
F	UP ARROW button	Increases a temperature setting
G	DOWN ARROW button	Decreases a temperature setting. Also mutes the audible alarm for five minutes.
H	SEL button	Toggles between alarm monitor and control modes

Label	Description	Function
I	ALARM DISABLE key switch	Disables all audible alarms. This switch does not affect alarm lamps or signals sent through the remote alarm interface.
J	SET lamp	Indicates a control or alarm setpoint is being changed
K	SET button	Accesses Configuration mode
L	CONTROL lamp	Indicates when the display is showing the refrigerator setpoint
M	MONITOR lamp	Indicates when the display is showing temperature readings from the monitor probe. Also indicates when alarm setpoints are being changed.
N	LIGHT switch	Turns the chamber light on or off

19.2 Viewing current settings

The monitoring and control system has alarms which activate if the chamber temperature is too high or too low. View the setpoints for these alarms, as well as other settings used to control and display the temperature.

The High Temp alarm setpoint specifies the temperature at which the High Temperature Alarm should activate. If the temperature detected by the chamber probe is greater than or equal to this value, the alarm activates. The default setpoint is +5.5 °C.

The Low Temp alarm setpoint specifies the temperature at which the Low Temperature Alarm should activate. If the temperature detected by the chamber probe is less than or equal to this value, the alarm activates. The default setpoint for HB (blood bank) models is +1.5 °C. The default setpoint for HPR (pharmacy/laboratory) models is +2.0 °C.

The Monitor Offset is used to calibrate the displayed temperature with the measured temperature. If the temperature displayed on the monitor does not match the actual chamber temperature, the setting for the Monitor Offset can be changed so they match. View the value for this setting. The default value varies for each refrigerator.

The Control Offset and Control Hysteresis are used to control the temperature of the chamber while the refrigerator is in use. These values are factory preset and should not be changed. The Control Offset default value varies for each refrigerator.

- 1 Press and hold both the **Up Arrow** and **Down Arrow** buttons for three seconds. The MONITOR lamp flashes to indicate program mode is enabled.
- 2 Press and release the **SEL** button until the desired setting appears.

If this lamp is flashing	Then this setting is selected
HIGH TEMP and MONITOR	High Temp alarm setpoint
LOW TEMP and MONITOR	Low Temp alarm setpoint
MONITOR only	Monitor Offset
CONTROL only	Control Offset
CONTROL only	Control Hysteresis

- 3 (Optional) To view the value for another setting, repeat step 2.
- 4 Press and hold both the **Up Arrow** and **Down Arrow** buttons for three seconds. The MONITOR lamp stops flashing to indicate an exit from program mode.

19.3 Changing settings

NOTE Information regarding descriptions and default values for general settings, alarm settings, and display settings is available in the i.C³ User Guide. The Control Offset and Control Hysteresis are factory preset and should not be changed.

19.3.1 Changing setpoints for chamber temperature alarms

The monitoring and control system has alarms which activate if the temperature is too high or too low. The setpoints for these alarms may be changed.

The High Alarm setpoint specifies the temperature at which the High Temperature Alarm should activate. If the temperature detected by the upper chamber probe is greater than or equal to this value, the alarm activates. The default setpoint is +5.5 °C. The setpoint can be changed from -40.0 °C to +25.0 °C.

The Low Alarm setpoint specifies the temperature at which the Low Temperature Alarm should activate. If the temperature detected by the upper chamber probe is less than or equal to this value, the alarm activates. The default setpoint for blood bank models is +1.5 °C. The default setpoint for pharmacy/laboratory models is +2.0 °C. The value can be changed to a value from -40.0 °C to +25.0 °C.

To change a temperature alarm setpoint

- 1 Press and hold both the **Up Arrow** and **Down Arrow** buttons for three seconds. The MONITOR lamp flashes to indicate program mode enable.
- 2 Press and release the **SEL** button until the desired setting appears.

If this lamp is flashing	Then this setting is selected
HIGH TEMP and MONITOR	High Temp alarm setpoint
LOW TEMP and MONITOR	Low Temp alarm setpoint
MONITOR only	Monitor Offset
CONTROL only	Control Offset
CONTROL only	Control Hysteresis

- 3 While pressing and holding the **SET** button, press and release the up arrow or down arrow button to change the value for the parameter.
- 4 When changes are complete, release the **SET** button.
- 5 (Optional) To change the value for another setting, repeat steps 2-4.
- 6 Press and hold both the **Up Arrow** and **Down Arrow** buttons for three seconds. The MONITOR lamp stops flashing to indicate an exit from program mode. The new settings are saved.

19.3.2 Calibrating the monitor readout

To ensure the high and low temperature alarms are activated properly, the chamber temperature that is read by the temperature probe must be accurate. Verify the probe is reading correctly by comparing the reading to that from an independent thermometer. After determining the appropriate temperature, change the monitor offset to match the value displayed on the monitor.

The monitor offset can be changed to a value from -10.0 °C to +10.0 °C.

Obtain:

- ▶ An independent thermometer, calibrated and traceable per national standards.
- ▶ Tape. This is used to secure the probe to the thermometer.

To calibrate the monitor readout

- 1 Measure the temperature of the probe bottle contents.
 - a Remove all probes and the cap from the bottle.
 - b Tape the independent thermometer to the temperature probe, and replace them in the bottle so their ends are immersed at least 2 inches (50 mm) in the solution.
 - c Allow the chamber temperature to stabilize for approximately 10 minutes.
 - d Obtain the reading from the independent thermometer.
- 2 Determine how to adjust the offset value.
 - a Compare the reading from the thermometer to that on the monitor.
 - ▶ Example 1 (monitor reading is too high): the monitor reading is +5.0 °C, and the thermometer reading is +4.5 °C
 - ▶ Example 2 (monitor reading is too low): the monitor reading is +3.0 °C, and the thermometer reading is +4.0 °C
 - b Determine how much to increase or decrease the offset value to make the monitor reading match the thermometer reading.
 - ▶ Example 1: decrease by 0.5 to match the thermometer reading.
 - ▶ Example 2: increase by 1.0 to match the thermometer reading.
- 3 Enter and save the offset value.
 - a Press and hold both the **Up Arrow** and **Down Arrow** buttons for three seconds. The MONITOR lamp flashes to indicate program mode enable.
 - b Press and release the **SEL** button until only the MONITOR lamp flashes. The monitor offset parameter is selected.
 - c While pressing and holding the **SET** button, do one of the following:
 - ▶ Press and release the **Down Arrow** button to decrease the offset value.
 - ▶ Press and release the **Up Arrow** button to increase the offset value.
 - d When changes are complete, release the **SET** button.
 - e Press and hold both the **Up Arrow** and **Down Arrow** buttons for three seconds. The MONITOR lamp stops flashing to indicate an exit from program mode. The new setting is saved.
- 4 Replace the probes in the probe bottle.
 - a Remove the thermometer and probe from the bottle and remove the tape from them.
 - b Screw the cap on the bottle, ensuring it fits tightly to minimize evaporation.
 - c Place the probes in the bottle, immersing them at least 2 inches (50 mm) in the solution.

19.3.3 Calibrating the evaporator probe

To ensure the refrigerator maintains the correct temperature, the evaporator temperature probe has been calibrated at the factory. Changing the calibration setting for the evaporator probe is not typically necessary, and should not be performed unless directed to do so by Helmer Technical Service.

19.4 Testing alarms

Test the alarms to ensure they are working correctly.

19.4.1 Testing chamber temperature alarms

The refrigerator has alarms that indicate if the chamber temperature becomes too high or too low. Test these alarms by placing the temperature probe in chilled or warm water and noting the temperature at which the alarm activates.



CAUTION

Testing alarms requires power disconnection. Protect items from extended exposure to adverse temperatures.

IMPORTANT

Complete the low alarm test before the high alarm test in order to control the temperature more easily and complete the testing more quickly.

Obtain:

- ▶ An independent thermometer, calibrated and traceable per national standards.
- ▶ Tape. This is used to secure the probe to the thermometer.
- ▶ One 8 oz (250 ml) glass half filled with chilled water, to hold the water used to measure temperature.
- ▶ One glass filled with crushed ice. This is used to cool the water.
- ▶ One 8 oz (250 ml) glass half full of warm water.



CAUTION

Temperature probes are fragile. Handle them with care.

- 1 Identify the current settings for the low alarm setpoint and high alarm setpoint.
- 2 Remove the chamber temperature probe from the probe bottle.
- 3 Tape the temperature probe to the thermometer, and immerse them in the glass of chilled water so their ends are toward the bottom of the glass. The warm water is used to warm the water in the probe glass.
- 4 Activate the Low Temperature Alarm with this method: While constantly stirring the thermometer and probe in the chilled water and watching the temperature on the monitor, slowly add ice so the temperature decreases 0.5 °C per minute. This is approximately 1 teaspoon (5 ml) of ice every 15 to 25 seconds. Be sure to keep the end of the thermometer and probe in the lower liquid and not in the upper ice. When the temperature reaches the low alarm setpoint, an alarm sounds and the LOW TEMP lamp flashes.
- 5 Note the temperature on the independent thermometer when the alarm was triggered.
- 6 Activate the High Temperature Alarm with this method: While constantly stirring the thermometer and probe in the chilled water and watching the temperature on the monitor, slowly add warm water so the temperature increases 0.5 °C per minute. When the temperature reaches the high alarm setpoint, an alarm sounds and the HIGH TEMP lamp flashes.
- 7 Note the temperature on the independent thermometer when the alarm was triggered.
- 8 Remove the thermometer and probe from the water and remove the tape from them.
- 9 Place the probe in the bottle, immersing it at least 2 inches (50 mm) in the solution.
- 10 Compare each thermometer value to its corresponding setpoint. If the values do not match, see chapter 16 (Troubleshooting) for information on how to proceed.

19.4.2 Testing the power failure alarm



CAUTION

Testing the power failure alarm requires that users disconnect power from the refrigerator, which may affect the chamber temperature. Before testing the alarm, take precautions to protect items in the refrigerator from extended exposure to adverse temperatures.

Test the power failure alarm to ensure it activates when AC power is lost.

During a power failure, the backup battery continues to provide power to the monitoring system.

- 1 Disconnect the refrigerator from power by switching the AC ON/OFF switch on the electrical box OFF. The power failure alarm should activate, causing the audible alarm to sound and P~~OFF~~ to appear on the display.
- 2 Power the refrigerator on by switching the AC ON/OFF switch on the electrical box ON. The power failure alarm should clear, causing P~~OFF~~ to clear from the display.

19.4.3 Testing the door open alarm



CAUTION

Testing the door open alarm requires the refrigerator door be left open for an extended period of time, which may affect the chamber temperature. Before testing the alarm, take precautions to protect items in the refrigerator from extended exposure to adverse temperatures.

Test the door open alarm to ensure it activates at the appropriate time.

The default timer value is set at 3 minutes and cannot be changed.

- 1 Open the refrigerator door and note the time. When the timer value is reached, the door open alarm should activate, causing the audible alarm to sound and the DOOR ALARM lamp to flash.
- 2 Close the refrigerator door. The door open alarm should clear, causing the audible alarm to clear and the DOOR ALARM lamp to stop flashing.

20 Warranty

20.1 Rel.i™ Product Warranty USA and Canada

For technical service needs, please contact Helmer at 800-743-5637 or www.helmerinc.com. Be sure to have the model and serial number available.

20.1.1 Rapid resolution

When a warranty issue arises it is our desire to respond quickly and appropriately. The service department at Helmer is there for you. Helmer will oversee the handling of your warranty service from start to finish. Therefore, Helmer must give advance authorization for all service calls and/or parts needs relating to a warranty issue. Any repeat service calls must also be authorized as well. This allows for proper diagnosis and action. Helmer will not be responsible for charges incurred for service calls made by third parties prior to authorization from Helmer. Helmer retains the right to replace any product in lieu of servicing it in the field.

20.1.2 Compressor

For the warranty period listed below, Helmer will supply the refrigeration compressor, if it is determined to be defective, at no charge, including freight. Helmer will not be liable for installation, refrigerant, or miscellaneous charges required to install the compressor beyond the first year of the warranty period.

- ▶ Horizon Series model compressor warranty period is five (5) years.

20.1.3 Parts

For a period of two (2) years, Helmer will supply at no charge, including freight, any part that fails due to defects in material or workmanship under normal use, with the exception of expendable items. Expendable items such as glass, filters, light bulbs, and door gaskets are excluded from this warranty coverage.

Inspection of defective parts by Helmer will be final in determining warranty status. Warranty procedures must be followed in all events.

20.1.4 Labor

For a period of one (1) year, Helmer will cover repair labor costs (including travel) and the cost of refrigerant and supplies necessary to perform authorized repairs. Repair service must be performed by an authorized Helmer service agency following the authorization process detailed above. Alternatively, your facility's staff may work with a Helmer technician to make repairs. Labor costs for repairs made by unauthorized service personnel, or without the assistance of a Helmer technician, will be the responsibility of the end user.

20.1.5 Additional warranty information

The time periods set forth above begin two (2) weeks after the original date of shipment from Helmer. Warranty procedures set forth above must be followed in all events.

THERE ARE NO WARRANTIES WHICH EXTEND BEYOND THE DESCRIPTION ON THE FACE HEREOF. THIS WARRANTY IS EXCLUSIVE AND IN LIEU OF ALL OTHER WARRANTIES, EXPRESS OR IMPLIED, INCLUDING WITHOUT LIMITATION ANY WARRANTY OF MERCHANTABILITY OR FITNESS FOR A PARTICULAR PURPOSE. NO WARRANTIES OF MERCHANTABILITY OR FITNESS FOR PARTICULAR PURPOSE SHALL APPLY.

THE LIABILITY, IF ANY, OF HELMER FOR DIRECT DAMAGES WHETHER ARISING FROM A BREACH OF ANY SALES AGREEMENT, BREACH OF WARRANTY, NEGLIGENCE, OR INDEMNITY, STRICT LIABILITY OR OTHER TORT, OR OTHERWISE WITH RESPECT TO THE GOODS OR ANY SERVICES IS LIMITED TO AN AMOUNT NOT TO EXCEED THE PRICE OF THE PARTICULAR GOODS OR SERVICES GIVING RISE TO THE LIABILITY. IN NO EVENT SHALL HELMER BE LIABLE FOR ANY INDIRECT, INCIDENTAL, CONSEQUENTIAL, OR SPECIAL DAMAGES, INCLUDING WITHOUT LIMITATION DAMAGES RELATED TO LOST REVENUES OR PROFITS, OR LOSS OF PRODUCTS.

This warranty does not cover damages caused in transit, during installation by accident, misuse, fire, flood, or acts of God. Further, this warranty will not be valid if Helmer determines that the failure was caused by a lack of performing recommended equipment maintenance (per Helmer manual) or by using the product in a manner other than for its intended use. Installation and calibration are not covered under this warranty agreement.

20.2 Outside of USA and Canada

Consult your local distributor for warranty information.

21 References and Compliance

21.1 Alarm reference

If an alarm condition is met, an alarm activates. Some alarms are visual only, while others are visual and audible. Some alarms are sent through the remote alarm interface.

The table below indicates if an alarm for a particular model is audible (A), visual (V), or sent through the remote alarm interface (R). Messages for visual alarms, if applicable, appear in the table as well.

Alarm	Alarm type
High Temperature	A, V, R
Low Temperature	A, V, R
Compressor Temperature	-
Door Open (Time)	A, V, R
Power Failure	A, V, R
Low Battery	-
Probe Failure	-
No Cellular Service	-

21.2 Energy conservation and regulatory compliance

This device complies with the requirements of directive 93/42/EEC concerning Medical Devices, as amended by 2007/47/EC.

This product is certified to applicable UL and CSA standards by a NRTL.

Insulation Type: 2

Pollution Degree: 2 (for use in USA and Canada only)

Sound level is less than 70 dB(A).



WEEE compliance

The WEEE (waste electrical and electronic equipment) symbol (right) indicates compliance with European Union Directive WEEE 2002/96/EC and applicable provisions. The directive sets requirements for the labeling and disposal of certain products in affected countries.



When disposing of this product in countries affected by this directive:

- ▶ Do not dispose of this product as unsorted municipal waste.
- ▶ Collect this product separately.
- ▶ Use the collection and return systems available locally.

For more information on the return, recovery, or recycling of this product, contact your local distributor.

END OF MANUAL

HELMER, INC.
14395 Bergen Boulevard
Noblesville, IN 46060 USA
Phone +1 (317) 773-9073
Fax +1 (317) 773-9082
www.helmerinc.com

